

# OPTIMAL DESIGN AND TECHNO-ECONOMIC ANALYSIS OF A HYBRID SOLAR-WIND POWER RESOURCE: A CASE STUDY AT AL BAHA UNIVERSITY, KSA

AHMAD F. TAZAY<sup>1</sup>, GAMAL A. W. HAZZA<sup>2</sup>, SALEM ZERKAOUTI<sup>1</sup> & SAEED A. ALGHAMDI<sup>1</sup>

<sup>1</sup>Electrical Engineering Department, Al Baha University, Al Aqiq, Al Baha, Saudi Arabia.

<sup>2</sup>Electrical Engineering Department, Faculty of Engineering, Sana'a University, Yemen.

## ABSTRACT

This study presents a feasibility analysis of supplying the measured load of Al Baha University in Saudi Arabia by renewable resources including solar photovoltaic (PV), wind turbine (WT), and storage banks instead of the current conventional grid. The objective of this paper is to find the optimum system that has the lowest net present cost (NPC) and greenhouse emission CO<sub>2</sub>. The metrological data and load profile are collected at the desired location. The simulation results show that NPC of a proposed combination of Grid/PV/WT system, at the current grid's tariff of 0.085\$/kWh, is more efficient than other configurations with power load shortage (<0.1%), with more than 30% reduction in CO<sub>2</sub> emission, and lower cost of energy (COE). The results also show that the integration of PV and WT sources with the main grid is the best configuration that leads to the minimum COE of 0.0772 \$/kWh, 0.075 \$/kWh, and 0.048 \$/kWh at the educational building, administration building, and total campuses' load, respectively. The developed methods conclude that the objective function and simulation results are feasible for the selected loads at Al Baha University. The current analyses can be adopted to install the real renewable energy system at the desired University.

*Keywords:* cost of energy (COE), feasibility analysis, net present cost (NPC), hybrid renewable energy system (HRES), power flow analysis.

## 1 INTRODUCTION

In 2012, the Kingdom of Saudi Arabia (KSA) was ranked as the world's largest oil producer with the second largest oil reserves having 266,455 million barrels of proven oil reserves [1]. However, in 2016, KSA was recorded as the world's 10th largest consumer of its total energy from fossil fuels of which 63% is crude oil and petroleum liquids-based and 37% natural gas [2]. A large proportion of fuel fossil consumption belongs to the electricity generation system, with more than 70% of this electricity consumed in the residential and commercial sectors [3]. Furthermore, according to the population and industry growth, the increasing demand for energy consumption puts more pressure on the economic and environmental sectors of KSA.

British Petroleum (BP) reported that KSA generated 571 million tons of carbon dioxide (CO<sub>2</sub>) in 2018 as one of the top producers of greenhouse emissions [4]. Therefore, the need to diversify energy is one of the major energy challenges in Saudi Arabia to determine the energy demand and ensure the oil reserves are appropriate for the lucrative export market size. The kingdom is working to develop alternative sources of energy, including nuclear energy and renewable energy, to meet domestic energy needs and free up oil and natural gas for export. On April 25, 2016, the government of KSA announced "Vision 2030" to improve Saudi's economy by depending on renewable resources. The target of producing energy from renewable resources was set to 9.5 GW by the end of 2030. Even renewable resources are available in the Arabian Peninsula; solar and wind energies are promising sources of non-hydrocarbon energy in the kingdom to supplement fossil fuel production in the next few decades [5].

A study in ref [6] indicated that the average daily solar radiation at KSA varies between 4 and 7.5 kWh/m<sup>2</sup>. According to SOLARGIS, the average annual sum of global horizontal radiation in the Arabian Peninsula is about 2200 kWh/m<sup>2</sup>/year [7]. The KSA has enough wind

energy potential with an average wind speed of 4–8 m/s [8]. The southern region of KSA has higher daily solar radiation and wind speed among other provinces. Since Saudi's electricity generation is governed by fossil fuels, generating energy from renewable resources for commercial and residential buildings will not only reduce the greenhouse emissions in KSA but will also improve the industrial and economic sectors [9, 10].

This study addresses the research gap with regards to a grid-connected hybrid renewable energy system (HRES) for an educational building as well as the following issues:

- Can the developed grid-connected HRES be reliable to supply the required load power to university buildings?
- What is the most economically viable grid-connected HRES system?
- Can the implementation of HRES reduce the dependence on fossil fuel and greenhouse emissions at KSA by considering the net present cost (NPC) as the basis for comparison?
- What are the payback time and sensitivity analyses for the optimal HRES configurations?

To answer these questions, the hourly load consumption, weather data, and the load profile for Al Baha University's buildings must be collected. Thus, the meteorological data were collected from KAPSARC and NASA during the years from 2003 to 2018. Then the identified data, which include meteorological data, equipment profile, optimization constraints, and search space, as well as load profile were introduced to the HOMER simulation software. The practical cost of each piece of equipment as well as the search space and constraints were specified to find the optimal configuration of the system. The technical and financial analyses were then compared to find the optimal system among the desired locations for the project lifetime. The environmental features were analyzed by comparing different cases. The sensitivity analysis that includes payback time, load variation, grid's tariff was conducted using the optimal configuration.

This study can be considered as a roadmap to meet the sustainability and resilience goals for university applications and load consumption in developed countries such as Saudi Arabia. The importance of this study is not only for considering renewable energy application at university campuses in KSA but can also be applied at any campus around the world. The significance of integrating renewable energy resources to share the load includes reducing the dependence on fossil fuels, decreasing the harmful emissions of carbon dioxide CO<sub>2</sub>, as well as increasing the efficiency and sustainability of the grid. In 2050, renewable energy can supply more than 75% of the total global energy demand; this could reduce by up to 94% of the CO<sub>2</sub> emissions [11]. It also helps to achieve the goals of KSA Vision 2030. The study has three novelties. First, the required load at different buildings of the university campus is supplied and compared by minimizing the cost of energy (COE) and NPC. Then, two advanced computer-aided analyses are performed to cover the technical and optimization approaches. Finally, the current analyses can be applied to any university in KSA and around the world with different load consumption and building types.

The rest of this paper is organized as follows. Section 2 reviews the relevant literature. Section 3 provides a detailed description of the analysis resources and meteorological data of the selected locations. Section 4 addresses the proposed hybrid system configuration. Section 5 examines the developed system by applying optimizations and sensitivity analysis. Section 6 presents the discussion of the feasibility analysis. Section 7 provides the conclusion and remarks.

## 2 LITERATURE REVIEW

Several literature studies exploring the performance of solar irradiation and wind speed at KSA have been published recently. Zell *et al.* summarized one-year solar resource measurements

from a monitoring network in KSA [12]. This paper focused only on analyzing the collection of solar resource data without considering the other renewable resources in the Arabian Peninsula. The analysis of current and future performance of solar and wind resources was evaluated in ref [13]. The study concluded that the southern region of KSA has higher daily solar irradiation and wind speed among other regions. The study did not mention the potential for power availability from renewable resources. Depending on renewable energy technology can not only solve the reliability and economic feasibility of electricity generation, but it can also improve the quality of life of people considering the availability of the resource [14].

The potential power generation from solar and wind resources in the KSA was analyzed in ref [15]. The research concludes that wind and solar resources in the KSA could generate 50 GW by the end of 2040. More optimal and analytical studies need to be pursued at different locations to assess the performance of solar and wind data in the KSA. A study in ref [16] proved that harvesting solar and wind energies instead of fossil fuel can be more realistic, competitive, and profitable to the kingdom for the next 50 years. Generating energy from solar and wind resources are the most trustworthy and reliable electrification resources. Even fuel cell systems have a considerable potential in generating and storing energies, the capital expenses will make the battery storage preferable for renewable resource systems [17].

The techno-economic analysis for grid-connected and off-grid systems at different cities in the Arabian Peninsula and KSA using a combination of HRES, such as PV, wind turbine, fuel-cells, and battery were provided in refs [18–25]. The authors in ref [18] reviewed the recent control strategies for energy management in hybrid renewable energy systems. This paper focused on the energy management strategies used in smart grids for both standalone and grid-connected hybrid renewable energy systems. The potential of supplying the load demand from renewable resources by considering a comparison of various locations at KSA was presented in ref [19]. The simulation results concluded that the off-grid system at Yanbu city has the minimum COE (0.609 \$/kWh) by integrating 2 kW of PV array, 3 kW of the wind turbine, 2 kW of the converter, and 7 battery storage banks with a nominal capacity of 253 Ah. Another study on the west coast of KSA investigated the potential of PV/Wind energy systems using HOMER and MATLAB [20]. The research concluded that PV energy had more economic features than solar energy with COE of 0.0637 \$/kWh and 0.149 \$/kWh, respectively. Krishna and Al-Talhi investigated the potential of renewable resources in the north region of KSA as compared with other cities [21]. The paper concluded that Tabuk city in the north region of KSA can generate 110,250 kWh annually from solar energy. The optimization model for an off-grid HRES at the southern region of KSA was analyzed in ref [22]. The optimization results showed that the lowest COE of the system was 0.289\$/kWh, which was based on PV/Wind/FC/battery with 176 kW of PV array, 20 kW of wind turbines, 98 kW of the fuel cell, and 11 batteries. The feasibility analysis of an autonomous system was presented in ref [23]. The authors compared three different optimization techniques using the MATLAB coding domain. As in the previous studies, they performed the feasibility analysis for residential load without considering the load consumed by commercial and educational buildings.

The study by Filho *et al.* highlighted the significant role played by universities around the world in the improvement of renewable resources with an emphasis on solar energy [24]. The huge engagement of universities to renewable resources has a great potential to reduce energy consumption and carbon emissions. Optimized design and performance of an off-grid system for an educational building at the University of Sharjah, UAE, was presented in ref [25]. The simulation results showed that the developed off-grid renewable energy system could meet the load demand with the best optimization results by sharing 73% of solar energy, 24% from fuel cells, and 3% from a diesel generator. Another study to optimize the size of a grid-

connected renewable energy system in the same area was carried out in ref [26]. The study concluded that connecting 500 kW of solar PV capacity and 100 kW of fuel cell capacity with the grid leads to a lower COE of 71 \$/MWh and a carbon dioxide emission of 133 kg/MWh. The developed system has 40.4% of renewable fraction and 5% of the sell-back energy to the grid. In ref [27], a different configuration of renewable resources was investigated using HOMER software at the Engineering Department of Islamic Azad University, Iran. The optimization results showed that the most economical hybrid system was based on a wind/diesel/battery hybrid system with nine wind turbines (20 kW), one diesel generator (300 kW), 50 batteries, and 50 kW power converters. The developed system could satisfy 1,174,935 kWh of an annual load demand of the university with an NPC of 4,281,800\$ and a COE of 0.285 \$/kWh. The study in ref [28] presented different metrological data at four university campuses in KSA. It provided feasibility and financial analyses of hybrid renewable energy systems at the selected campuses. The study concludes that Al Baha University has the most potential energy generation among other university campuses in KSA.

The KSA has more than 38 public and private higher education institutions that are primarily connected to the Saudi Electricity Company of the national grid. Even with the high potential of wind and solar energies in KSA, few projects for renewable resources research have been implemented at local universities [29]. The contribution of commercial and educational buildings in energy consumption from renewable resources can achieve the KSA Vision 2030.

### 3 DESCRIPTION OF THE CASE STUDY

The location of Al Baha University campus is selected for analyzing the metrological data. The available resources at the desired location include solar irradiation, wind speed, and temperature data. Al Baha University is located at latitude 20°17' N and longitude 41°38' E as shown in Fig. 1; this has the advantage of high solar irradiation and high wind speed since it is in the region of 30° north of the earth's equator. The meteorological data are obtained from the NASA website and King Abdullah City for Atomic and Renewable Energy (K.A. CARE) and compared with the installed weather stations at selected sites [7, 30]. The detailed monthly meteorological data are given in the following subsections.

#### 3.1 Solar irradiation data

The monthly variation of average solar energy at Al Baha University site is given in Fig. 2. The peak solar irradiation occurs in the summer season, while it decreases in the winter months. The figure shows that the average solar irradiation is approximately 5.84 kWh/m<sup>2</sup>. The collected data are applied for over 20 years at the selected location. The peak solar irradiation is observed in May at 7.08 kWh/m<sup>2</sup>, while the lower one occurs in December at 4.23 kWh/m<sup>2</sup>.

#### 3.2 Wind speed data

The average variation of a monthly wind speed at Al Baha University site is given in Fig. 3. It is thus recognized that the wind speed is high at the desired location from July to August. The Al Baha University site has an average annual wind speed of approximately 5.01 m/s. The peak wind speed is approximately 5.99 m/s, while the lowest one is approximately 4.1 m/s.

#### 3.3 Temperature data

Recording the temperature is important to the evaluation of the sizing and performance of the proposed system since it has an impact on the output energy of renewable resources. Figure 4



Figure 1: Topology of the developed system at Al Baha University.

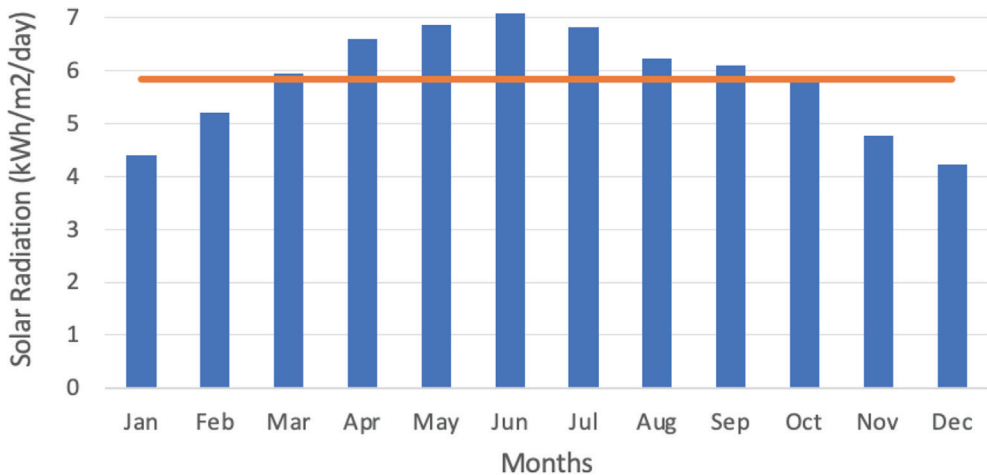

Figure 2: Monthly solar irradiation at the selected location.

shows the monthly variation of temperature at Al Baha University site. The average temperature is approximately 25.16 °C which is suitable for a better performance of renewable resources. The peak average temperature is 30.53 °C, while the lower recorded temperature is 17.65 °C.

### 3.4 Load profile

The load at Al Baha University is measured in three cases, namely the load of educational building, the load of administration building, and the total annual load of Al Baha University. The current load of the desired location depends on the main grid. The annual load demand of the three measured cases is given in Figs. 5, 6, and 7. The energy consumption of electricity is mainly shared by air-conditioning, lighting, and laboratory equipments.

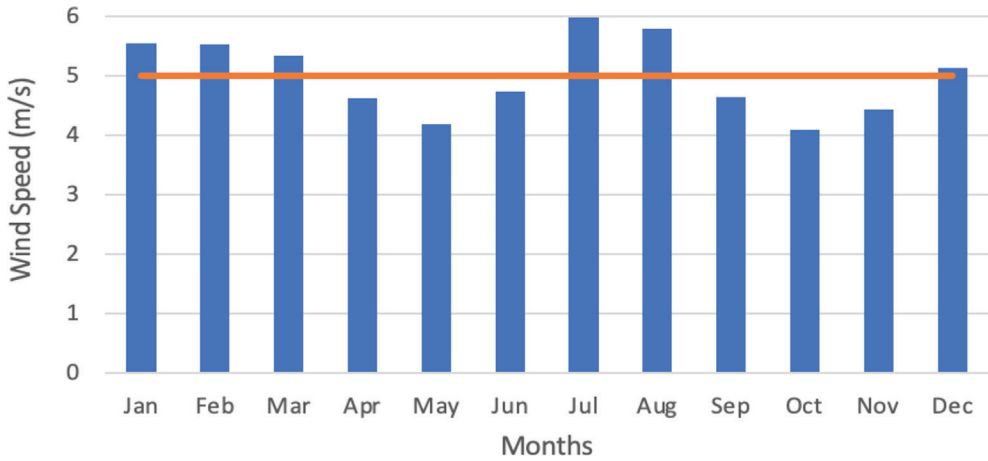

Figure 3: Monthly average wind speed at Al Baha University.

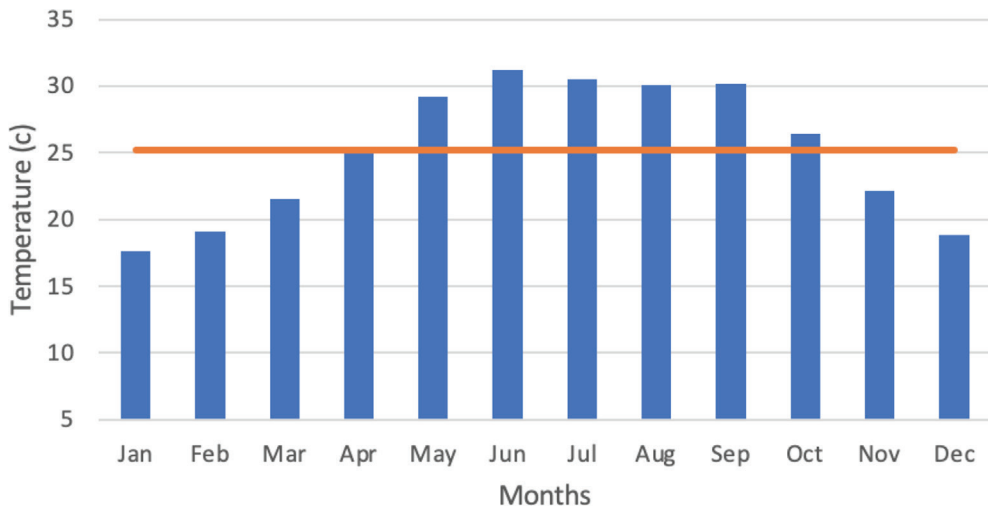

Figure 4: Monthly average temperature at Al Baha University.

The average energy demand of the educational building is approximately 13,507 kWh/day, while the daily average load is 563 kW. Figure 5 shows the monthly measured average load of the educational building. The peak load occurs during the summer season because of the high temperature and operation of air condition units. The peak load of 1,800 kW occurs in August.

The average energy demand of the administration building is approximately 24,303 kWh/day, while the daily average load is 1,013 kW. Figure 6 shows the monthly measured average load of the administration building. The peak load occurs during the summer season with a peak of 2,562 kW. The reason for high load consumption is because of air condition and administrative tasks of employees.

The measured total monthly load consumption is shown in Fig. 7. The average energy demand at Al Baha University is approximately 195,298 kWh/day, while the daily average load is 8,137 kW. The peak load of approximately 8,000 kW occurs in August. This load

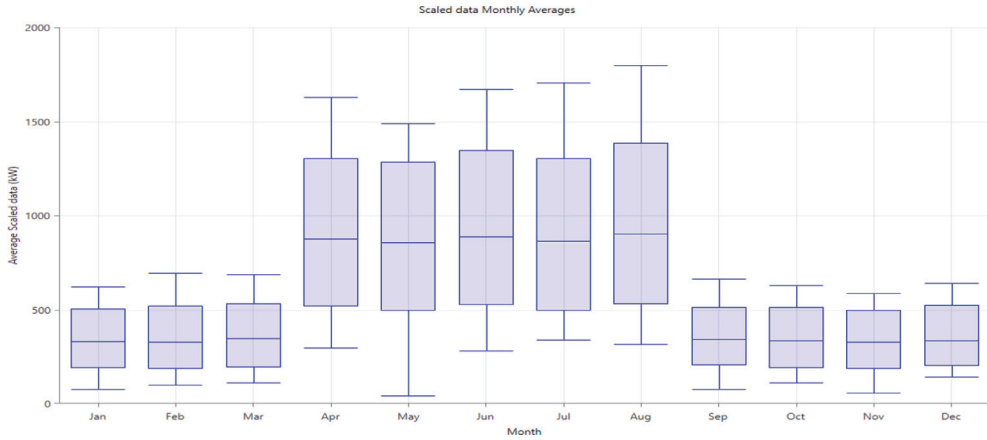

Figure 5: Annual load demand of the educational building at Al Baha University.

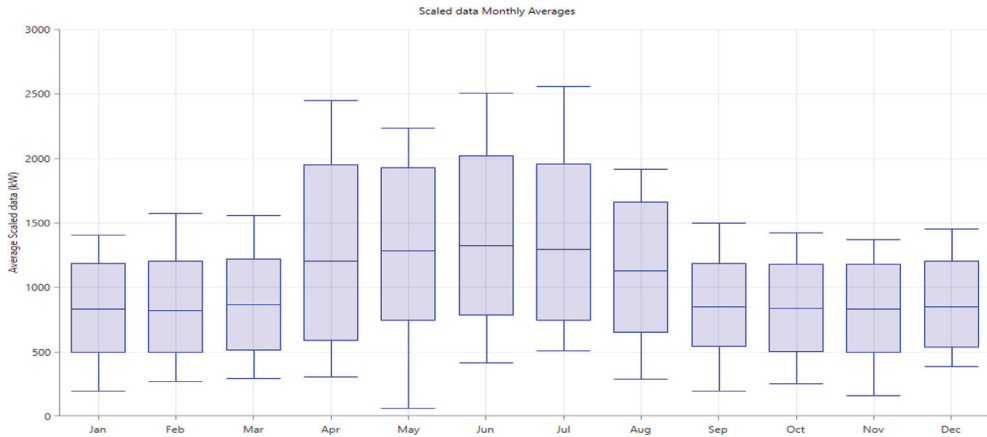

Figure 6: Annual load demand of the administration building at Al Baha University.

consumption involves all campus buildings, residential and student housing, and other facilities. Since the main grid supplies the required load consumption at Al Baha University, the need for renewable resources is essential to reduce the total consumption cost.

### 3.5 Electric grid of Al Baha University

The distribution network at Al Baha University is connected with the electricity grid of the Saudi Electricity Company (SEC) through two 33 kV overhead lines. The university distribution network consists of 13.8 kV underground cables and 13.8kV/400V distribution transformers that supply the various buildings at the campus [30].

## 4 PROPOSED HYBRID SYSTEM CONFIGURATION

The proposed HRES system consists of a PV array, DC/AC converter, wind turbine (WT), and battery bank. The interconnection of the system components was simulated in the HOMER software tool, and their technical and economic specifications were provided for

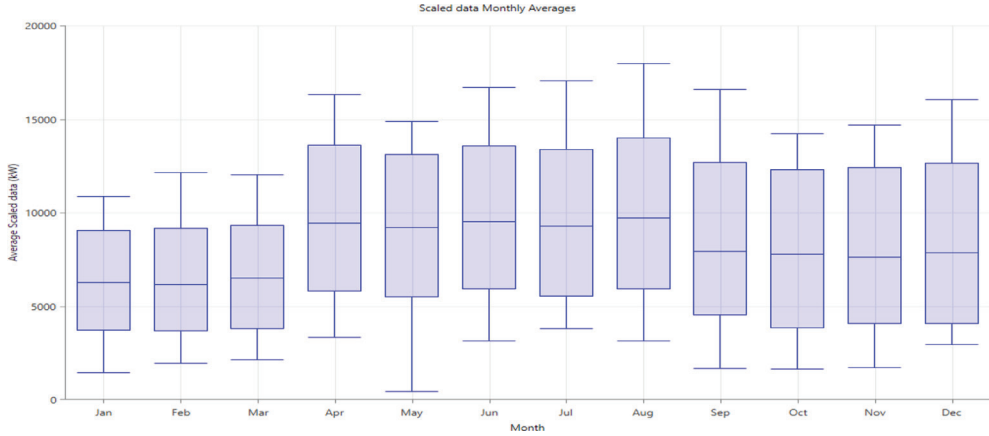

Figure 7: Total annual load demand of Al Baha University.

simulation purposes. The HRES is designed to operate at grid-connected or autonomous modes as shown in Fig. 8. Depending on the weather conditions, renewable energy (solar and wind) systems with a battery storage device were used to supply electricity to the whole load as well as for meeting the peak demand time. In contrast, the grid was connected only in the event of any shortfall in supply to ensure continuous operation and to charge the storage battery depending on the type of dispatch strategies used.

The different meteorological data at the considered locations are used to optimize each component of the system. Figure 8 shows the case of an educational building while the rest of the loads have the same system structure. The cost and the sizing data of the main components used in this analysis are given in detail in Table 1.

## 5 SIMULATION AND RESULTS

The developed system is designed to operate at autonomous and grid-connected modes to satisfy the required load demand. Three different combinations of developed systems are simulated using computer-aided renewable energy simulation tool (HOMER) and PowerWorld. These systems are designed based on Al Baha University loads that include an administration building, education building, and total university buildings. The configurations of the system are examined to meet the minimum NPC and COE at each determined load. The load profile, meteorological restriction, optimization constraints, and monetary data are used as input information to the model.

The goal of the simulation procedure using HOMER is to find the optimal configuration of each developed system that provides zero load demand and lower NPC. Then, the optimal system will be used for sizing and investigating the power flow using PowerWorld simulation. The search space and constraints of the objective function are selected based on the following steps:

- The search space of the PV array is varied from 0 to 10,000 kW.
- The search space of wind turbine is varied from 0 to 10,000 kW.
- The size of the battery bank is changed from 0 to 10,000 units of batteries.
- The DC/AC converter is selected between 0 and 10,000 kW.
- The project's lifetime is set to be 20 years.



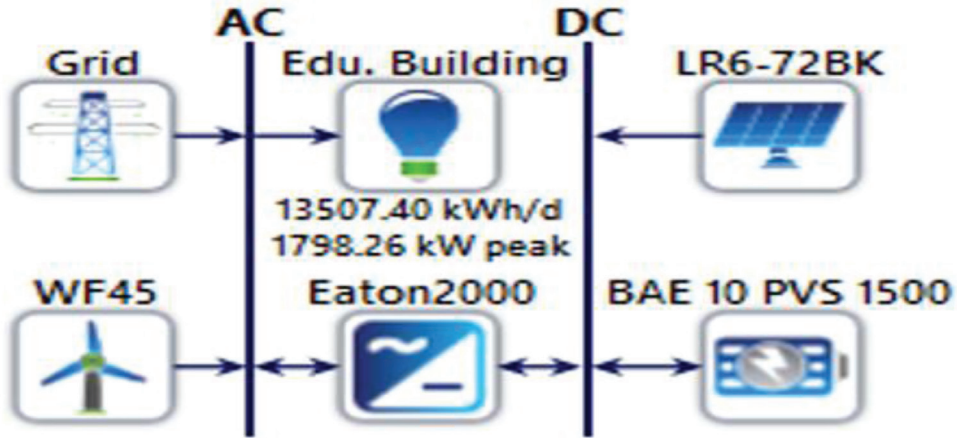

Figure 8: Schematic diagram of the developed system at Al Baha University

Table 1: Technical and economic characteristics of system’s components.

Element	Installation (\$)	Replacement (\$)	O&M (\$/y)	Lifetime (y)	P (kW)	V (V)	I (A)
Grid	40,000	0	0	$\infty$	33,000	33000	1,000
PV	550	550	10	20	0.35	37.7	9.28
WT	650,000	650,000	80	20	500	690	725
Battery	600	600	30	8	2.67	2	1,335

The optimization process for the desired site is given in a flowchart in Fig. 9. The input data to the model contain daily load consumption at each building, meteorological information at the university, economic data, sizing of each component, and project constraints. The HOMER software suggests the optimal configurations based on minimizing the objective function using Graham Algorithm. The optimal configurations are achieved when the system meets the load demand and accomplishes constraints. The previous methodology has simulated for each selected load by the PowerWorld simulator [31]. The load flow analysis was conducted for the three load types to ensure that underground cables and distribution transformers were not overloaded. The optimization procedures for the feasibility analysis are carried out in the following steps:

1. Record the required weather data and load demand of the selected location.
2. Identify the constraints of the objective function.
3. Set up the sizing and cost of each component of the system.
4. Searching the optimal system by defining the number of iterations that meet the load demand.
5. Present the NPC and COE of the optimal system.
6. Repeat the previous process for different university buildings.
7. Apply the sizing of the optimal system to PowerWorld simulation.

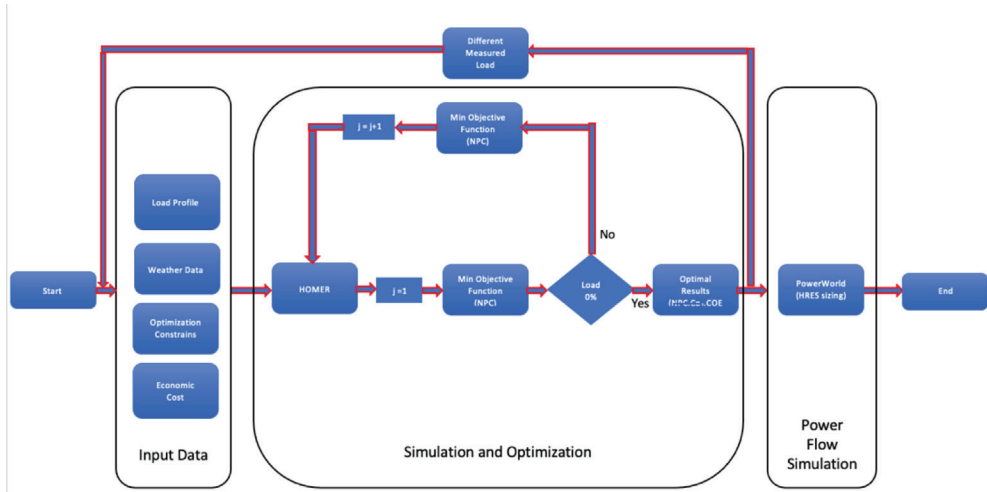

Figure 9: Flow chart of the simulation and optimization techniques.

### 5.1 Technical evaluation

Figure 10 shows the contribution of the electrical sources of the proposed hybrid system to cover the electrical load of the educational buildings at the university. The energy purchased from the Saudi electricity grid covers approximately 75% of the electrical loads in the summer period and 55% in the winter period. Renewable energy sources cover the rest of the electrical load, which represents 25% of the electrical load in summer and 45% in winter.

Figure 11 shows the contribution of the electrical sources of the proposed hybrid system to cover the electrical load of the administration building at the university. The energy purchased from the Saudi electricity grid covers approximately 60% of the electrical loads in the summer period and 59% in the winter period. Renewable energy sources cover the rest of the electrical load, which represents 40% of the electrical load in summer and 50% in winter.

Figure 12 shows the contribution of the electrical sources of the proposed hybrid system to cover the electrical load of the campus buildings at the university. The energy purchased from the Saudi electricity grid covers approximately 45% of the electrical loads during the year. Renewable energy sources cover the rest of the electrical load, which represents 55% of the electrical load.

### 5.2 Economic evaluation

Figure 13 shows the NPC of the optimal hybrid systems suggested options to supply the different loads of Al Baha University. The optimum options that have the lowest NPC are demonstrated. The suitable option can be implemented according to the availability of financial and technical capabilities and resources of the university.

### 5.3 Environmental impact assessment

The detailed pollutant emissions of the possible options of optimum hybrid systems are listed in Table 2. In comparing all options with the grid-only connected system, the latter has the highest emissions.

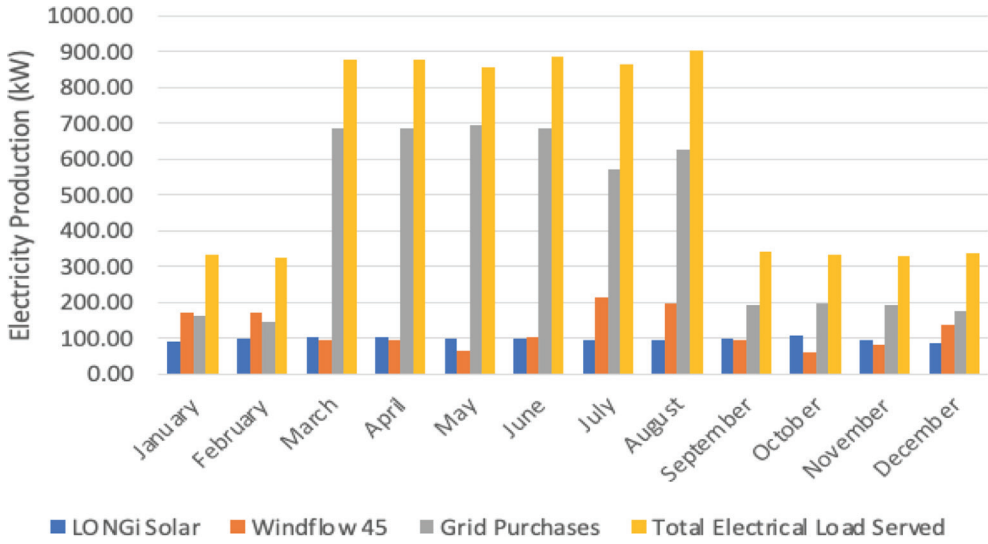

Figure 10: Monthly energy production for the education building.

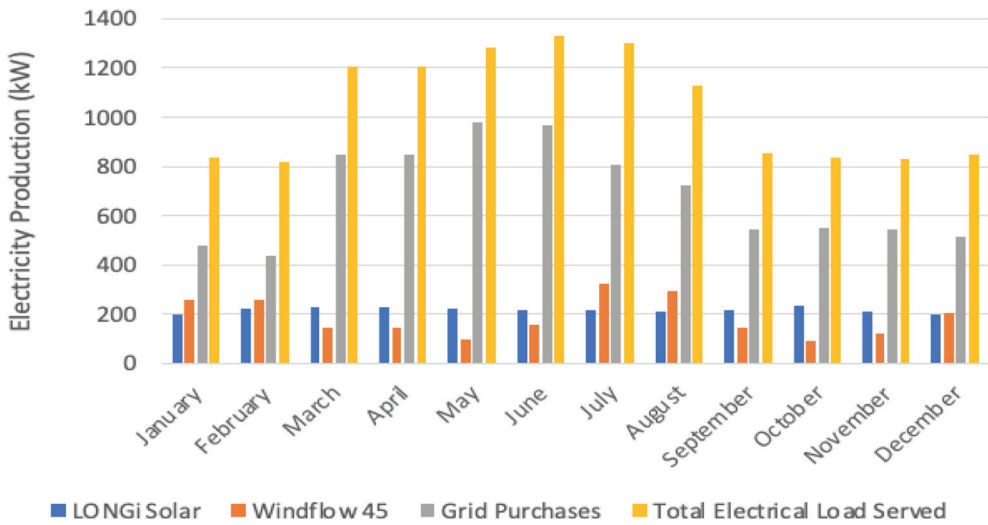

Figure 11: Monthly average energy production for the administration building.

#### 5.4 PowerWorld simulator results for the optimal hybrid system

The detailed case study is prepared and simulated using the PowerWorld (PW) simulator, which is a computer-aided simulator and easy to exchange power flow cases of different energy resources [30]. Different case studies have been modeled and developed by the authors to investigate the potential of installing real applications of renewable resources at Al Baha University, KSA. The suggested models of different case studies have been given in detail in Figs. 14–16.

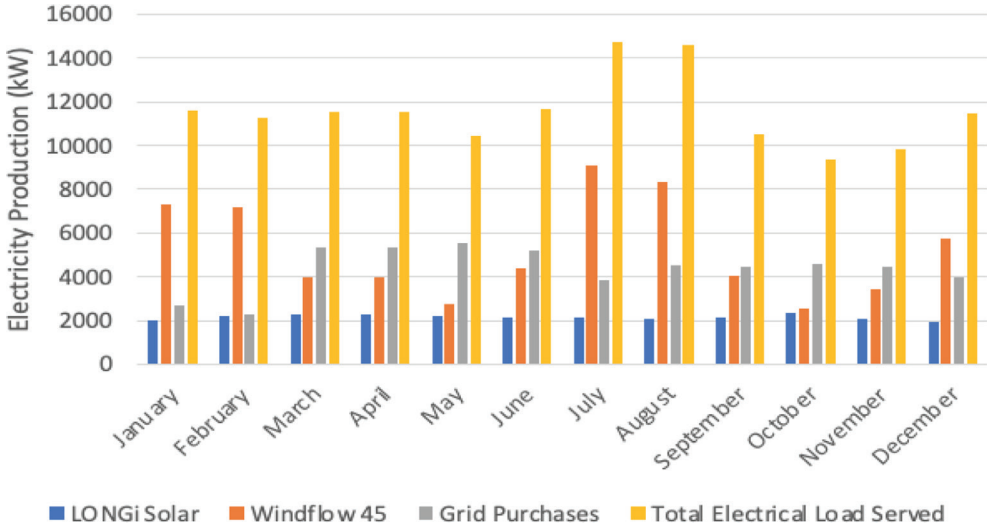

Figure 12: Monthly average energy production for the campus buildings.

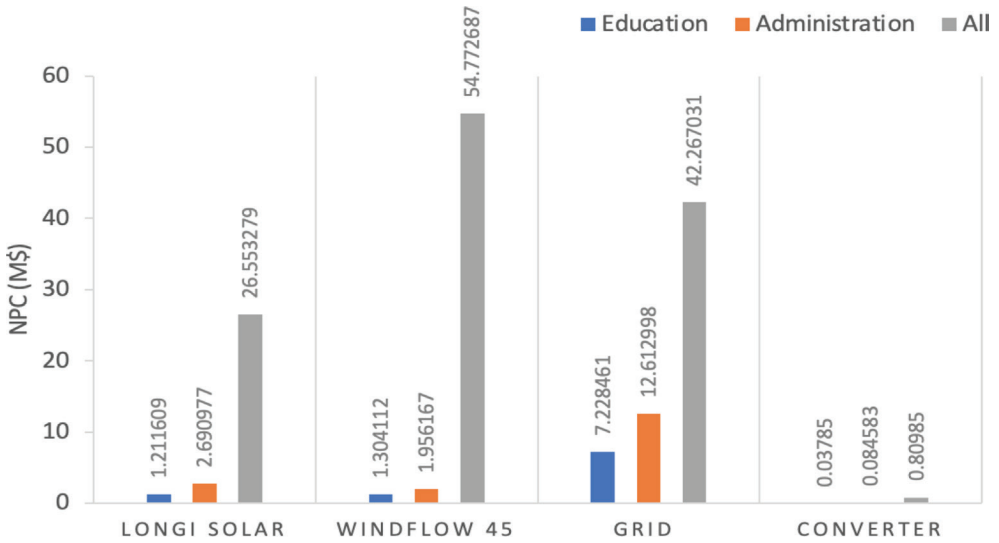

Figure 13: NPC of the three options of the optimal hybrid systems.

The methodology of load flow is summarized in the following major steps:

- Step 1: Technical and statistical data of Al Baha University distribution network have been collected.
- Step 2: The collected technical and statistical data changed to per unit quantities based on nominal voltage values and 100 MVA.
- Step 3: Data are adopted with the requirements of the PW simulator.
- Step 4: The electrical single-line diagram is built and edited by the PW simulator.
- Step 5: Load flow and power loss are conducted for the three load cases.

Figure 14 shows the first case study of the designed system to install renewable resources at the educational building. The distributed small PV and WT resources can be installed in the educational buildings to meet the load demand of each building. The excess generated power can be used to satisfy the closest building's load demand as illustrated in Fig. 14.

The high load demand in the administration building requires a large amount of renewable resources, which is suggested to have values of 1 MW of PV and 1.5 MW of WT as shown in Fig. 15. The developed RE system in the administration building can meet more than 35% of the total load demand. This system can improve the reliability of the system and decrease the COE of the total generated power.

The final case study is designed to generate the required power for the total university load from RE resources. A huge amount of RE resources can be installed at the main distributed line as given in Fig. 16. The developed RE system can meet a partial load demand, while the main grid feeds the remaining consumed load. It is worth mentioning that the generated power can only be used to meet the local load because of the main grid's capability as shown in Fig. 16. Thus, the generated power from RE resources cannot be sold to the main electric grid to avoid any disturbance at the distributed feeder.

Table 2: Detailed environmental results of the different options.

Element	Education	Administration	All
Carbon dioxide (kg/y)	2,079,911	3,637,873	22,771,680
Carbon monoxide (kg/y)	0	10,303	64,496
Unburned hydrocarbon (kg/y)	0	1,151	7,206
Particular matter (kg/y)	0	806	5,044
Sulphur dioxide (kg/y)	9,017	8,462	52,966
Nitrogen dioxide (kg/y)	4,410	92,098	576,498

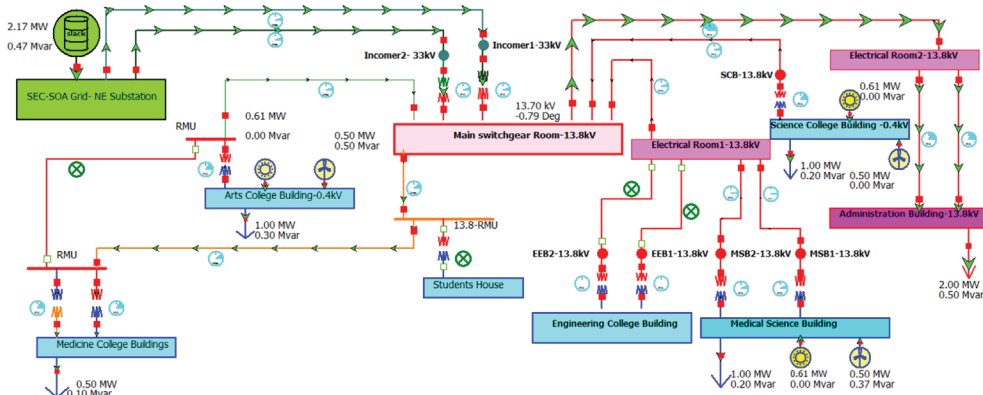

Figure 14: Power flow solution of installed RE sources at the educational building.

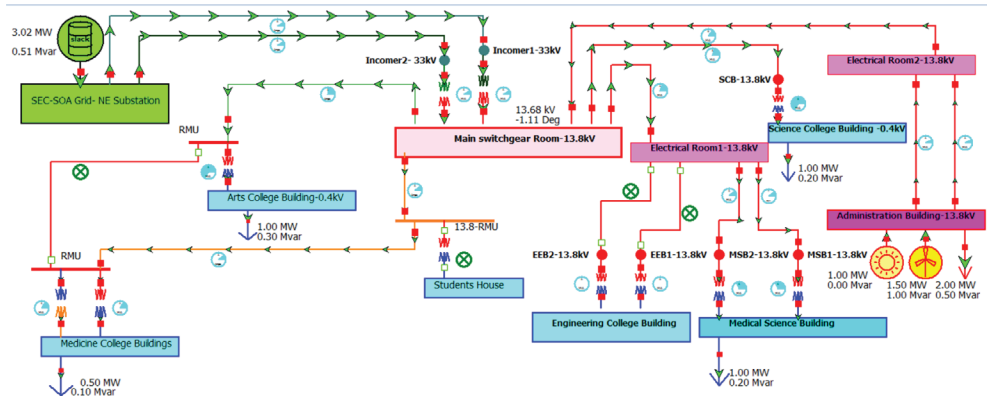

Figure 15: Power flow solution of installed RE sources at the administration building.

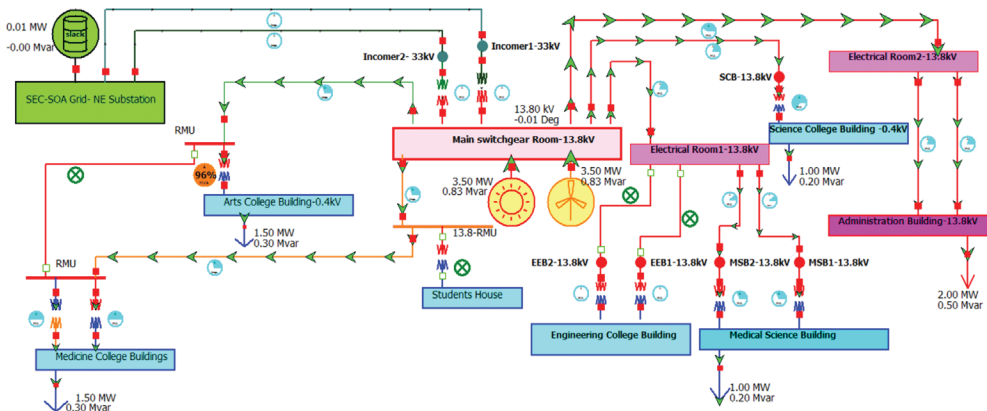

Figure 16: Power flow solution of installed RE sources at the 13.8 kV main substation.

### 5.5 Comparison analysis

#### 5.5.1 Grid-only system

The current electric mode of Al Baha University is grid-connected whereby the load is connected to the Saudi Electricity Company (SEC-SOA) grid. The load demand is covered by the SEC-SOA grid where there are no renewable sources. The total NPC for the three cases of the university’s load over the 20 years project lifetime is given in Table 3. The current electricity tariff from the SEC-SOA for commercial buildings is 0.085 \$/kWh, which includes the operational cost and fossil fuel prices.

It can be seen from Table 3 that the energy consumption produces high annual CO<sub>2</sub> emissions because of connecting to the main grid. This emission is approximately 45,051,488 kg/year for the total university load, which needs to be decreased for environmental concerns.

#### 5.5.2 Grid-connected hybrid system

The technical and economic optimization for all load cases is given in Tables 4, 5, and 6. The load demand involves administration building, education building, and the total university

Table 3: Current components of grid-connected systems for different university loads.

<b>Load Type</b>	<b>NPC (\$)</b>	<b>COE (\$/kWh)</b>	<b>Operating Cost (\$/y)</b>	<b>Production (kWh/y)</b>	<b>Consumption (kWh/y)</b>	<b>CO<sub>2</sub> (kg/y)</b>
Education	10.8M	0.0853	419,067	4,930,200	4,930,200	3,115,886
Administration	25.8M	0.0851	754,013	8,870,744	8,870,744	5,606,310
Total loads	156M	0.0850	6,060,233	71,284,000	71,284,000	45,051,488

load. The RF of all cases is more than 30%, which could decrease the CO<sub>2</sub> emissions. The CO<sub>2</sub> emission varies from 2M kg/year to 35M kg/year for educational load and total load, respectively. This configuration provides a significant reduction of CO<sub>2</sub> emission compared with a grid-only system.

The total energy production from the grid-connected HRES system varies from 181,712 kWh/year to 255,285 kWh/year. It can be recognized from the data in Tables 5, 6, and 7 that the Grid/PV/WT system can provide lower NBC and COE compared with the other configurations. The optimal system also provides high RF value and low CO<sub>2</sub> emission.

The optimal configuration of the simulation process is selected to achieve the optimum objective function and satisfy the constraint. The most valuable configuration is the one that has minimum COE and NPC. The configuration of Grid/PV/WT provides a lower NPC and COE comparing with other system combinations at the current grid's tariff. It should also have an annual load demand shortage of less than 0.1%. It can be recognized from the data in Tables 4–6 that the combination of different sizing of Grid/WT/PV has the minimum COE for all selected loads.

The results in Table 4 show that the configuration of the Grid/WT/PV system has the minimum COE of 0.0772 \$/kWh. The optimal sizing of the system is 525 kW PV array, 1,000 kW of WT, and 378 kW AC/DC converter. The developed system of an educational building can minimize about 33% of CO<sub>2</sub> emissions comparing with the grid-only system. This configuration can provide the required load of the educational building at Al Baha University without any load shortage.

The developed Grid/PV/WT in Table 5 presents the lowest COE for the administration building. The COE of the system is 0.0750 \$/kWh, while the NPC is 22.8 M\$. The sizing of the grid-connected HRES is 1,236 kW PV array, 1,500 kW WT, and 908 kW AC/DC converter. The HRES array shares 35.9% of the building's load, and the system generates annually 3.5M kg of CO<sub>2</sub>.

In the total load consumption of Al Baha University, the optimization results show that Grid/PV/WT configuration represents the lowest COE with 0.048 \$/kWh and 124 M\$ of NPC. Comparing with the current operation of the load connecting with the main grid, this configuration shows a significant reduction in COE of the main grid (0.0853 \$/kWh). The optimal sizing of the system is 11,517 kW PV array, 42,000 kW of WT, and 8,098 kW AC/DC converter. Since the RF of HRES is approximately 64%, a considerable reduction in CO<sub>2</sub> emission can be obtained.

### 5.5.3 Off-grid system

The HRES covers the load demand where the grid is absent. The optimal size of the HRES is given in Table 7. The HRES provides the required load demands for the three case studies.

Table 4: Optimization results of the educational building.

System	PV (kW)	WT (kW)	AC/DC (kW)	Battery (kW)	COE (\$/kWh)	NPC (\$)	RF (%)	Prod. (kWh/y)	Cons. (kWh/y)	CO <sub>2</sub> (kg/y)
Grid/PV/WT	525	1,000	378	0	0.0772	9.78M	33.2	5,283,450	4,930,200	2,079,911
Grid/WT	0	1,000	0	0	0.0791	10.0M	19.5	5,104,407	4,930,200	2,508,872
Grid/PV	675	0	674	0	0.0804	10.2M	20.8	5,006,456	4,930,200	2,467,320
Grid/PV/WT/B	531	1,000	393	8,000	0.234	29.7M	33.4	5,285,843	4,930,200	2,076,046
Grid/WT/B	0	1,000	7	8,000	0.236	29.9M	19.5	5,104,407	4,930,200	2,508,872
Grid/PV/B	802	0	562	8,000	0.237	30.0M	23.7	5,070,078	4,930,200	2,376,887

Table 5: Optimization results of the administration building.

System	PV (kW)	WT (kW)	AC/DC (kW)	Battery (kW)	COE (\$/kWh)	NPC (\$)	RF (%)	Prod. (kWh/y)	Cons. (kWh/y)	CO <sub>2</sub> (kg/y)
Grid/PV/WT	1,236	1,500	908	0	0.0750	22.8M	35.9	9,401,522	8,870,774	3,591,062
Grid/WT	0	2,500	0	0	0.0775	23.5M	24.8	9,508,592	8,870,774	4,216,649
Grid/PV	1,825	0	1,608	0	0.0783	23.8M	29.6	9,224,187	8,870,774	3,947,267
Grid/PV/WT/B	1,227	1,500	900	8,000	0.163	49.3M	35.8	9,396,386	8,870,774	3,596,971
Grid/WT/B	0	2,500	3	8,000	0.165	50.1M	24.8	9,508,592	8,870,774	4,216,649
Grid/PV/B	1,701	0	1,199	8,000	0.166	50.3M	28.2	9,147,717	8,870,774	4,026,786



Table 6: Optimization results of the total campus loads.

System	PV (kW)	WT (kW)	AC/DC (kW)	Battery (kW)	COE (\$/kWh)	NPC (\$)	RF (%)	Prod. (kWh/y)	Cons. (kWh/y)	CO <sub>2</sub> (kg/y)
Grid/PV/WT	11,517	42,000	8,098	0	0.0480	124M	64.3	102,486,208	100,814,432	22,771,680
Grid/WT	0	47,000	0	0	0.0513	128M	64.3	98,662,368	97,331,200	28,650,328
Grid/PV	9,741	0	7,139	0	0.0789	145M	21.7	72,010,720	71,629,848	35,461,612
Grid/PV/WT/B	13,630	40,000	10,104	8,000	0.0554	144M	65.4	102,673,760	101,209,688	22,143,304
Grid/ WT /B	0	47,000	58	8,000	0.0592	148M	53.4	98,662,368	97,331,200	28,650,328
Grid/PV/B	23,549	0	18,141	8,000	0.0758	160M	45.9	82,831,048	82,022,976	28,055,926

Table 7: Optimization results of different loads of off-grid HRES.

System	PV (kW)	WT (kW)	AC/DC (kW)	Battery (kW)	COE (\$/kWh)	NPC (\$)	RF (%)	Prod. (kWh/y)	Cons. (kWh/y)	CO <sub>2</sub> (kg/y)
Education	5,295	6,000	2,522	8,000	0.317	40.2M	100	15,451,525	4,928,168	0
Administration	10,142	5,500	3,129	10,000	0.239	72.4M	100	22,766,324	8,868,329	0
Total loads	28,378	45,000	25,481	8,000	0.0477	149M	75	46,321,576	58,500,000	18,950,082

The NPC and COE of each different load are also provided. It can be seen from Table 7 that the NPC is significantly increased because of the presence of energy storage. It is worth mentioning that the HRES could not cover the total load of the university because of the huge load demand and reliability purposes. Thus, the highest RF of the system can reach 75%, which is acceptable for reducing the CO<sub>2</sub> emission.

## 6 DISCUSSION

The integration of PV array and wind turbines to the main grid can decrease the COE production for most of the building loads. As seen in Tables 4, 5, and 6, the energy storage can be neglected by integrating PV and wind turbines with the main grid. These tables also show that the system configuration of PV, wind turbines, and the main grid is the optimal system that provides the lowest COE and NPC among all configurations. It is worth mentioning that operating the proposed system in an autonomous mode can be achieved for single buildings. Thus, installing PV and wind turbines to share the total loads of the university can not only reduce the NPC of the system for the project period, but it can also reduce the harmful emission of CO<sub>2</sub>.

COE is a good indicator for comparing the cost of the proposed systems in different case studies by considering the NPC. The nominal COE for educational, administration, and all university loads are 0.0772 \$/kWh, 0.0750 \$/kWh, and 0.0450 \$/kWh, respectively. The NPC for the optimal configurations is competitive with the electricity company tariff, which is more than 0.0850 \$/kWh for consumption of more than 71,000 kWh. The current NPC measurement of energy supplied from the main grid is approximately 25.8 M\$ for the administration building. Integrating PV and wind turbines with the main grid, by avoiding any energy storage, would reduce the NPC by up to 22.8 M\$.

The detailed environmental analysis of all case studies is listed in Tables 4, 5, and 6. The optimal system of PV/WT/Grid could reduce the harmful emission by more than 30% depending on the case study and connection mode. The factor of RF plays a significant role in reducing harmful emissions. Thus, integrating renewable resources can not only reduce COE and NPC of the proposed project during the lifetime period, but it can also reduce the harmful emissions of the system.

## 7 CONCLUSION

The investigation of different configurations of supplying energy power generation is presented for various university load demands at Al Baha University, KSA. Three types of meteorological data, namely solar radiation, wind speed, and temperature, are measured and used in this study at the desired location. Three types of load consumption at Al Baha University are considered at autonomous and grid-connected modes. The technical and economic as well as power load flow analyses are carried out at the proposed location using the computer-aided HOMER and PowerWorld simulators.

Based on the simulation results, it has been demonstrated that, for all load cases, the proposed Grid/PV/WT configurations generate a lower energy cost (NPC < 0.0772\$/kWh), achieve less than 0.1% of power load shortage and more than 30% reduction in CO<sub>2</sub> emission, which indicates the economic viability of the system. Electric power flow analysis validates the technical effectiveness of the proposed optimal configurations. It is worth mentioning that operating the proposed system at an autonomous mode can be achieved for a

single building, but it performs with the worst economic prospects (NPC is significantly increased), which makes its implementation a non-viable option.

The current analyses can be adopted to install an actual renewable energy system at the study location and can also serve as a reference for similar renewable energy projects at other university buildings in Saudi Arabia.

In future research, a sensitivity analysis of the selected site as well as a performance analysis of a large-scale hybrid grid-connected solar wind will be attempted for various locations in the Al Baha region.

#### ACKNOWLEDGMENT

The authors extend their appreciation to the Deputyship for Research & Innovation, Al Baha University, Ministry of Education in Saudi Arabia, for funding this research work through the project number: MOE-BU-8-2020.

#### CONFLICT OF INTEREST

The authors declare that there is no conflict of interest regarding the publication of this paper.

#### APPENDIX

The meteorological data are collected from the NASA website and King Abdullah City for Atomic and Renewable Energy (K.A.CARE) as well as from the installed weather stations on the selected sites at Al Baha University. The electric transmission line characteristics and consumed load data are obtained from the Saudi Electricity Company (SEC-SOA). The authors got the authority to use these data based on the funded research. The data that support the findings of this study are available from the corresponding author upon reasonable request. However, readers can access the data, including the location, metrological data, and electric grid characteristics, by contacting online representatives at the following links:

- Saudi Arabia Renewable Resource Atlas [Internet]. RRATLAS. Available from: <https://rratlas.energy.gov.sa/RRMMPublicPortal/>
- Atmospheric Science Data Center [Internet]. NASA Langley Research Center. Available from: <https://eosweb.larc.nasa.gov>
- Saudi Electric Company [Internet]. SEC. Available from: <https://www.se.com.sa/en-us/Pages/home.aspx>

The distribution network of the BU campus consists of two 33 kV feeders that are connected to Al-Baha East Main Substation that belongs to the SEC through two 33 kV overhead lines. The main BE s/s steps down the 132kV transmission voltage of the South Region of Saudi Arabia to 33kV sub-transmission and distribution voltage. From 33 kV busbar, two feeders (F3, F4) go out to feed the university campus that is located 19.773 km away from the substation. The two 33 kV feeders are connected with two mobile distribution substations that step down from 33 kV to 13.8 kV. Low voltage sides of mobile transforms connect to the main switchgear room through 15 kV underground cables. The 13.8 kV distribution network consists of 15 kV underground cables feeding the university buildings from the main switchgear room through the ring main units room. There are four 13.8 kV outgoing feeders that supply all educational, administrative buildings, student housing building, and housing for faculty members as shown in Fig. 17.

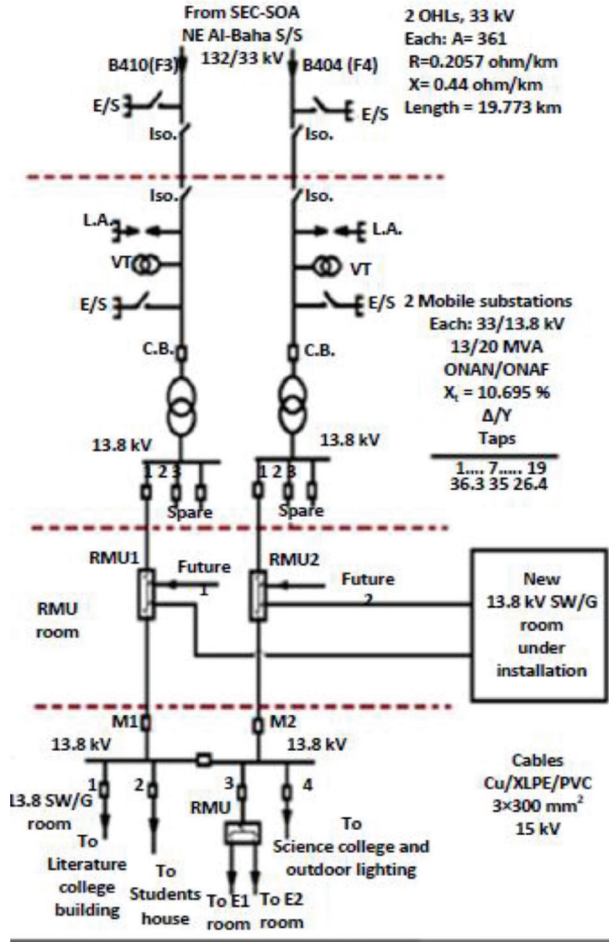

Figure 17: 33 and 13.8 kV power supply of the BU campus.

REFERENCES

- [1] The World Bank. World Development Indicators [Internet]. DataBank; c2020, <https://databank.worldbank.org/source/world-development-indicators>. Accessed on: 12 February 2020.
- [2] Middle East Economic Survey. Saudis Slash Subsidies as Oil Revenue Collapses, Volume 59, Issue 1.8, January 2016.
- [3] KAPSARC Data Portal [Internet]. Electricity Consumption by Sectors, <https://data-source.kapsarc.org/explore/dataset/electricity-consumption-by-sectors/>. Accessed on: 13 February 2020.
- [4] Statistical BP. Review of World Energy [Internet]. BP; c2020, <https://www.bp.com>. Accessed on: 15 August 2020.
- [5] Dike, J.C., Does climate change mitigation activity affect crude oil prices? Evidence from dynamic panel model. *Journal of Energy*, **2014**, p. 514029, 2014.

- [6] Esmail, K.K., Alshitawi, M.S. & Almasri, R.A., Analysis of energy consumption pattern in Saudi Arabia's residential buildings with specific reference to Qassim region. *Energy Efficiency*, **12(8)**, pp. 2123–2145, 2019. <https://doi.org/10.1007/s12053-019-09806-x>
- [7] SOLAR-GIS. Solar resource maps of Saudi Arabia [Internet], c2020, <https://solargis.com/maps-and-gis-data/download/saudi-arabia>. Accessed on: 12 February 2020.
- [8] RRATLAS. Saudi Arabia Renewable Resource Atlas [Internet], c2021, <https://rratlas.energy.gov.sa/RRMMPublicPortal/>. Accessed on: 10 February 2020.
- [9] Maleki, A., Design and optimization of autonomous solar-wind-reverse osmosis desalination systems coupling battery and hydrogen energy storage by an improved bee algorithm. *Desalination*, **435**, pp. 221–234, 2018.
- [10] Tazay, A.F., Ibrahim, A.M.A., Noureldeen, O. & Hamdan, I., Modeling, control, and performance evaluation of grid-tied hybrid PV/wind power generation system: case study of Gabel El-Zeit region, Egypt. *IEEE Access*, **8**, pp. 96528–96542, 2020. <https://doi.org/10.1109/access.2020.2993919>
- [11] Gielen, D., Boshell, F., Saygin, D., Bazilian, M.D., Wagner, N. & Gorini, R., The role of renewable energy in the global energy transformation. *Energy Strategy Reviews*, **24**, pp. 38–50, 2019.
- [12] Zell, E., Gasim, S., Wilcox, S., Katamoura, S., Stoffel, T., Shibli, H. & Al Subie, M., Assessment of solar radiation resources in Saudi Arabia. *Solar Energy*, **119**, pp. 422–438, 2015.
- [13] Alharbi, F. & Csala, D., Saudi Arabia's solar and wind energy penetration: future performance and requirements. *Energies*, **13(3)**, p. 588, 2020. <https://doi.org/10.3390/en13030588>
- [14] Oladigbolu, J.O., Ramli, M.A. & Al-Turki, Y.A., Feasibility study and comparative analysis of hybrid renewable power system for off-grid rural electrification in a typical remote village located in Nigeria. *IEEE Access*, **8**, pp. 171643–171663, 2020.
- [15] Ramli, M.A., Twaha, S. & Al-Hamouz, Z., Analyzing the potential and progress of distributed generation applications in Saudi Arabia: the case of solar and wind resources. *Renewable and Sustainable Energy Reviews*, **70**, pp. 287–297, 2017.
- [16] Hossain, M., Mekhilef, S. & Olatomiwa, L., Performance evaluation of a stand-alone PV-wind-diesel-battery hybrid system feasible for a large resort center in South China Sea, Malaysia. *Sustainable Cities and Society*, **28**, pp. 358–366, 2017.
- [17] Olatomiwa, L., Mekhilef, S., Ismail, M.S. & Moghavvemi, M., Energy management strategies in hybrid renewable energy systems: a review. *Renewable and Sustainable Energy Reviews*, **62**, pp. 821–835, 2016.
- [18] Hailu Kebede, M. & Bekele Beyene, G., Feasibility study of PV-wind-fuel cell hybrid power system for electrification of a rural village in Ethiopia. *Journal of Electrical and Computer Engineering*, **2018**, p. 4015354, 2018.
- [19] Olatomiwa, L., Mekhilef, S., Huda, A.S.N. & Ohunakin, O.S., Economic evaluation of hybrid energy systems for rural electrification in six geo-political zones of Nigeria. *Renewable Energy*, **83**, pp. 435–446, 2015.
- [20] Al-Sharafi, A., Sahin, A.Z., Ayar, T. & Yilbas, B.S., Techno-economic analysis and optimization of solar and wind energy systems for power generation and hydrogen production in Saudi Arabia. *Renewable and Sustainable Energy Reviews*, **69**, pp. 33–49, 2017.
- [21] Krishna, L.V. & Al Thalhi, F.A., Solar and wind energy potential in the Tabuk region, Saudi Arabia. *International Journal of Applied Science and Technology*, **5(3)**, pp. 12–22, 2015.

- [22] Ramli, M.A., Hiendro, A. & Al-Turki, Y.A., Techno-economic energy analysis of wind/solar hybrid system: case study for western coastal area of Saudi Arabia. *Renewable energy*, **91**, pp. 374–385, 2016.
- [23] Tazay, A.F., Samy, M.M. & Barakat, S., A techno-economic feasibility analysis of an autonomous hybrid renewable energy sources for university building at Saudi Arabia. *Journal of Electrical Engineering & Technology*, **15(6)**, pp. 2519–2527, 2020.
- [24] Leal Filho, W., Salvia, A.L., Do Paco, A., Anholon, R., Quelhas, O.L.G., Rampasso, I.S. & Brandli, L.L., A comparative study of approaches towards energy efficiency and renewable energy use at higher education institutions. *Journal of Cleaner Production*, **237**, p. 117728, 2019.
- [25] Ghenai, C. & Bettayeb, M., Modelling and performance analysis of a stand-alone hybrid solar PV/Fuel Cell/Diesel Generator power system for university building. *Energy*, **171**, pp. 180–189, 2019.
- [26] Ghenai, C. & Bettayeb, M., Grid-tied solar PV/fuel cell hybrid power system for university building. *Energy Procedia*, **159**, pp. 96–103, 2019.
- [27] Fazelpour, F. & Soltani, N., Feasibility study of renewable energy resources and optimization of electrical hybrid energy systems: case study for Islamic Azad University, South Tehran Branch, Iran. *Thermal Science*, **21(1 Part A)**, pp. 335–351, 2017.
- [28] Tazay, A., Techno-economic feasibility analysis of a hybrid renewable energy supply options for University Buildings in Saudi Arabia. *Open Engineering*, **11(1)**, pp. 39–55, 2021.
- [29] NASA Langley Research Center. Atmospheric Science Data Center [Internet], c2021, <https://eosweb.larc.nasa.gov>. Accessed on: 30 February 2021.
- [30] Hazza, G.A.W., Proposed PV systems for Al Baha University at Al-Baha Region, Saudi Arabia. *Al Baha University Journal of Basic and Applied Sciences (BUJBAS)*, **5(1)**, pp. 11–23, 2021.
- [31] Power World Corporation c2021, [www.powerworld.com](http://www.powerworld.com). Accessed on: 30 March 2021.