

A Low Noise and Power Efficient 45nm GPDK Technology based Highly Stable Current Balancing Logic (HCBL) and Dynamic Logic Circuits for Mixed Signal Systems

*S Seenuvasamurthi, **G Nagarajan

* Department of ECE, Research Scholar, Pondicherry University, India, Pondicherry Engineering College, Pondicherry, (seenu_er@yahoo.co.in)

** Department of ECE, Professor, Pondicherry University, India, Pondicherry Engineering College, Pondicherry, (nagarajanpec@pec.edu)

Abstract

Noise is an important factor in the analog and digital circuits which determine the characteristics of the system. There are many sources of noises. Power supply noise caused by circuit switching, crosstalk noise due to capacitive coupling between neighboring interconnects, fluctuations in device parameters due to process variations, noise due to charge sharing and charge leakage in high speed dynamic logic circuits. The work aims at developing a noise robust circuit with high frequency response. The same circuit can be implemented in a dynamic logic system with reduced number of transistor. Also the dynamic logic will have the probability of signal switching activity to be low which will subsequently reduce the power of the system. The circuits have been constructed using cadence ADE and the same has been simulated with Spectra using 45nm GPDK technology. The simulation results show that the power consumption has been reduced multi-fold and the bandwidth has been increased by 10^2 Hz and the delay is reduced by 50%

Keywords

Current Balanced Logic, pseudo-NMOS, Noise immunity, Dynamic logic

1. Introduction

Building noise is an important factor in VLSI circuits. Noise is defined as any deviation of a signal from its nominal value in those sub-intervals of time when it should otherwise be stable [1]. Noise in digital circuits can be attributed to several sources, such as power supply noise, charge sharing noise, leakage noise and crosstalk noise. During design, rigorous noise analysis and noise considerations are becoming increasingly important. The

following trends in modern digital IC design accentuate the need for careful and detailed consideration of noise during circuit design and optimization. Lowering the Supply voltages, leading to smaller margins for noise; Transistors threshold voltages are being lowered, leading to higher levels of leakage noise; Circuits are being packed closer together, leading to increased coupling and crosstalk noise; Signals have faster rise and fall times, leading to more power supply noise; The increased use of dynamic circuitry for performance reasons worsens the susceptibility to noise problems.

Charge-sharing noise problems are often avoided by appropriate sizing of transistors. When a circuit is optimized, in addition to criteria such as delay, power, noise and area should be considered. The mathematical expression for noise consideration in circuit optimization is in the form of a non-linear semi-infinite problem [2-3]. Moreover, the number of signals that must be checked for noise violations and the number of subintervals of time during which these checks must be performed are potentially large. Hence, the incorporation of noise considerations during circuit optimization is an arduous task and no practical solution exists in the literature.

The rest of the paper is described as follows. The section II discuss about the previous predominant works in this domain. Section III explains about the proposed circuit its construction, working and the mathematical model for the small signal equivalent. Section IV discuss about the simulation results and their interpretation. Section V concludes the work.

2. Previous works

There are many works which has been reported on this noise immunity circuit building. This work takes a few close references from the Current Balanced Logic (CLB) for the proposed circuit. Fig.1 achieves ideally constant supply current by using a diverse principle. They may be regarded as pseudo-NMOS circuits [3], [4] to which transistor M_3 has been added. The aim is that, during logic transitions, the variation of i_{D3} compensates (or balances and hence, the designation current balanced logic) the variation of i_{D2} [5], [6]. It is observed that a perfect compensation can be obtained, thus making $i_{D3} + i_{D2} = I_{DD}$ constant as shown in Fig. 3, if transistors M_2 and M_3 are matched.

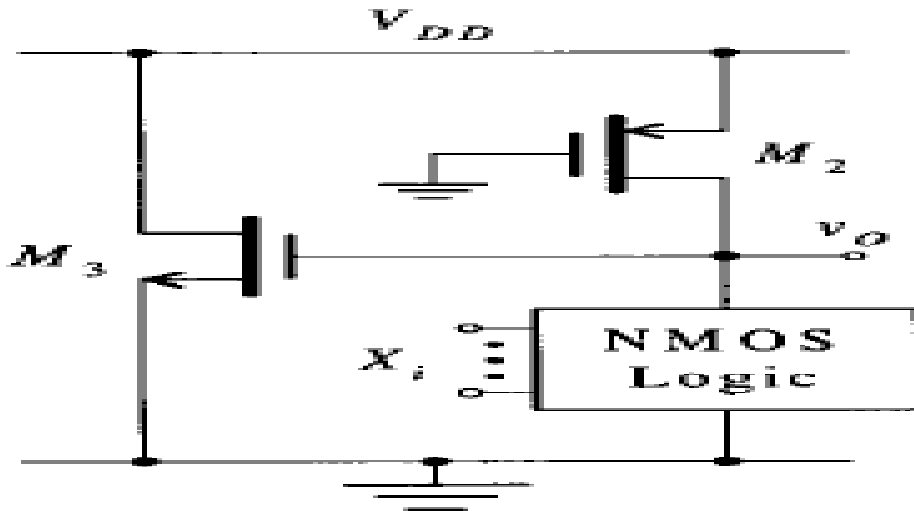

Fig.1. Current Balanced Logic family

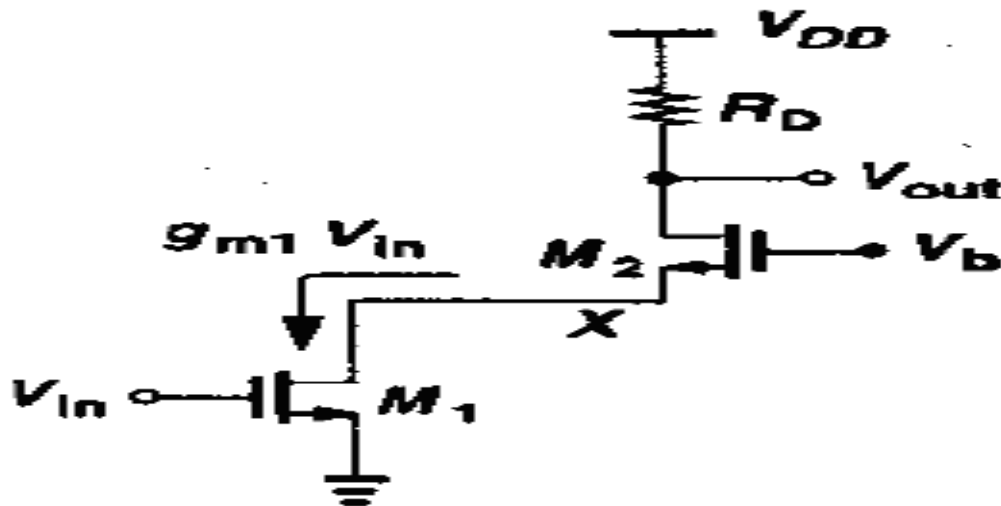

Fig.2. Gain improvement circuit

$$V_{tn} = V_{tp} = V_t \quad (1)$$

$$K_3 = K_2 = K \quad (2)$$

$$K_3 = \frac{1}{2} [\mu_n C_{ox} W_3/L_3] \quad (3)$$

$$K_2 = \frac{1}{2} [\mu_p C_{ox} W_2/L_2] \quad (4)$$

where, K is the constant, V_{tp} and V_{tn} are the threshold voltages of the PMOS and NMOS transistors, respectively and with the usual meaning for (mobility), C_{ox} (gate oxide capacitance) and $W=L$ (aspect ratio). It is straight forward to show that $i_{D3} + i_{D2} = I_{DD}$. Thus, a constant supply current is obtained for all values of V_O , to the degree that M_2 and M_3 are matched (simulations show that mismatches [7], [8] of up to 10% have little effect on the amplitude of the supply current spikes). The usage of dynamic logic also improves the power since it reduces the switching activity of the logic to a great extent. This work aim for developing a dynamic logic with feedback structure to reduce the leakage loss and transitions in the output.

3. Proposed work

This work aim for developing a circuit with high gain with reduced mismatch so as to reduce the noise in the circuits. The concept of cascade structure will improve the gain of the proposed structure and the same will also act as shielding structure for reducing the noise by reducing the mismatch in the proposed circuit. The same concept can be illustrated by a mathematical small signal model to show the gain of the proposed structure has improved.

3.1 Gain improvement by cascode

Consider the circuit in Fig.2 with input signal given to MOSFET. It's known that a transistor in a common-source arrangement converts a voltage signal to current signal [9]. MOSFET M_2 is cascade on the top of M_1 which provides many useful properties. In the Fig.2 M_1 generates a small signal drain current proportional to V_{in} and M_2 simply routes the current to R_D .

It is notated that, M_1 the input device and M_2 the cascade device. Note that in this circuit, M_1 and M_2 carry equal currents. The attributes of the circuit is described in this section and many advantages of the cascode structure over a simple common-source stage become evident. For M_1 to operate in saturation $V_x \geq V_{in} - V_{th}$. If M_1 and M_2 are both in saturation, the V_x is determined primarily by

$$\begin{aligned} V_x &= V_b - V_{gs2}. \text{ Thus,} \\ V_b - V_{gs2} &\geq V_{in} - V_{th1} \text{ and hence} \\ V_b &> V_{in} + V_{gs2} - V_{th1}. \end{aligned} \tag{5}$$

For M_2 to be saturated,

$$\begin{aligned} V_{out} &\geq V_b - V_{th2}, \text{ that is} \\ V_{out} &\geq V_{in} - V_{th1} + V_{gs2} - V_{gs2} \end{aligned} \tag{6}$$

Equations (5) and (6) provide the necessary biasing condition for getting the high gain structure. V_b is chosen to place M_1 at the edge of saturation [10]. Consequently, the minimum output level for which both transistors operate in saturation is equal to the overdrive voltage of M_1 plus that of M_2 . In other words, addition of M_2 to the circuit reduces the output voltage swing by at least the overdrive voltage of M_2 . M_2 is stacked on top of M_1 and now analysing the large-signal behaviour of the cascode stage shown in Fig. 3 as V_{in} goes from zero to V_{DD} . For $V_{in} \leq V_{th1}$, M_1 and M_2 are off. $V_{out} = V_{DD}$ and $V_x = V_b - V_{th2}$. As V_{in} exceeds V_{th1} , M_1 begins to draw current and V_{out} drops. Since I_{D2} increases, V_{GS2} must increase as well, causing V_x to fall.

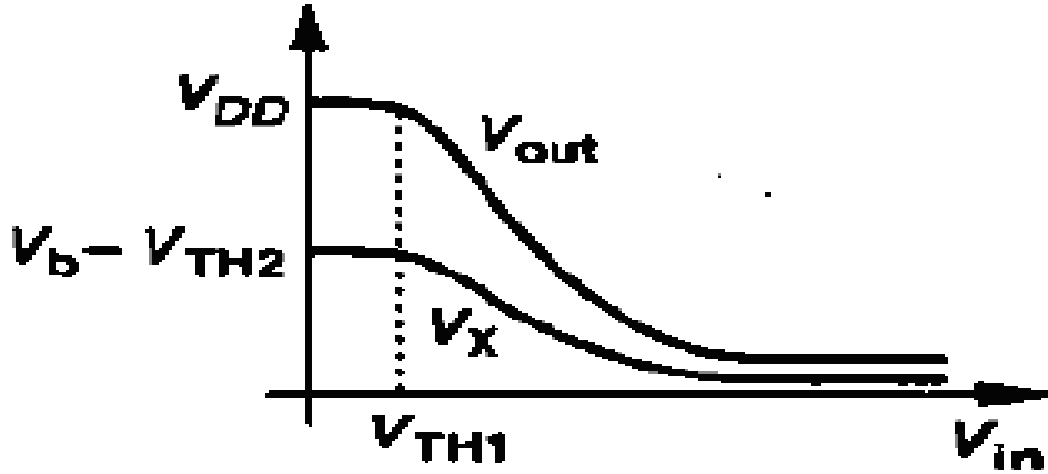

Fig.3. Input output characteristics of a cascode stage

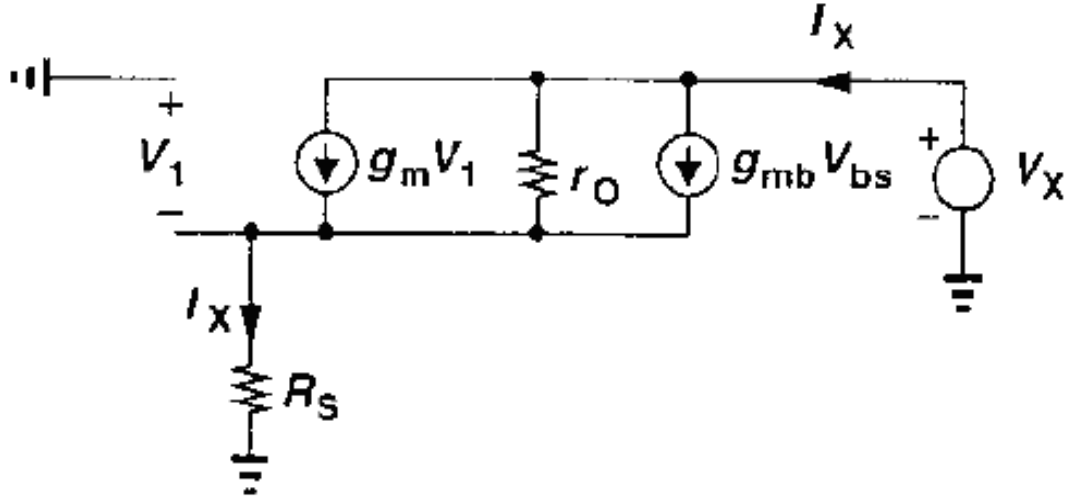

Fig.4. Large signal analysis

As V_{in} assumes sufficiently large values, two effects occur: (1) V_x drops below V_{in} by V_{th1} , forcing M_1 into the triode region; (2) V_{out} drops below V_b by V_{th2} , driving M_2 into the triode region. Depending on the device dimensions and the values of R_D and V_b , one effect may occur before the other. For example, if V_b is relatively low, M_1 may enter the triode region first. Note that if M_2 goes into deep triode region, V_x and V_{out} become nearly equal. To understand the effect of cascode on R_{out} let us mathematically analyze as described below. A small signal equivalent circuit including the effect of body bias is developed and it is shown in Fig.4.

Since the current through R_s is equal to I_x , $V_1 = -I_x R_s$ and the current flowing through 'r_o' is given by

$$I_x - (g_m + g_{mb}) V_1 = I_x + (g_m + g_{mb}) R_s I_x \quad (7)$$

Adding the voltage drops across r_o and R_s we obtain

$$r_o [I_x + (g_m + g_{mb}) R_s I_x] + I_x R_s = V_x \quad (8)$$

It follows that

$$\begin{aligned} R_{out} &= [1 + (g_m + g_{mb})R_s] r_o + R_s \\ &= [1 + (g_m + g_{mb})r_o]R_s + r_o \end{aligned} \quad (9)$$

Since typically $(g_m + g_{mb})r_o \gg 1$, we have

$$\begin{aligned} R_{out} &\approx (g_m + g_{mb})r_o R_s + r_o \\ &= [1 + (g_m + g_{mb}) R_s] r_o \end{aligned} \quad (10)$$

Indicating that the output resistance will be increased by a factor of $[1 + (g_m + g_{mb}) R_s]$. Since R_{out} increases the gain will also get increased, because Gain $(G) = -g_m \cdot R_{out}$, where g_m is the trans-conductance and R_{out} is the output resistance. Similarly the small-signal characteristics of a cascode stage by assuming both transistors operate in saturation. If $\lambda = 0$, the voltage gain is equal to that of a common-source stage because the drain current produced by the input device must flow through the cascode device [11-12]. Fig. 5 shows the small signal equivalent of the circuit in Fig.3, this result is dependent of the trans-conductance and body effect of M_2 .

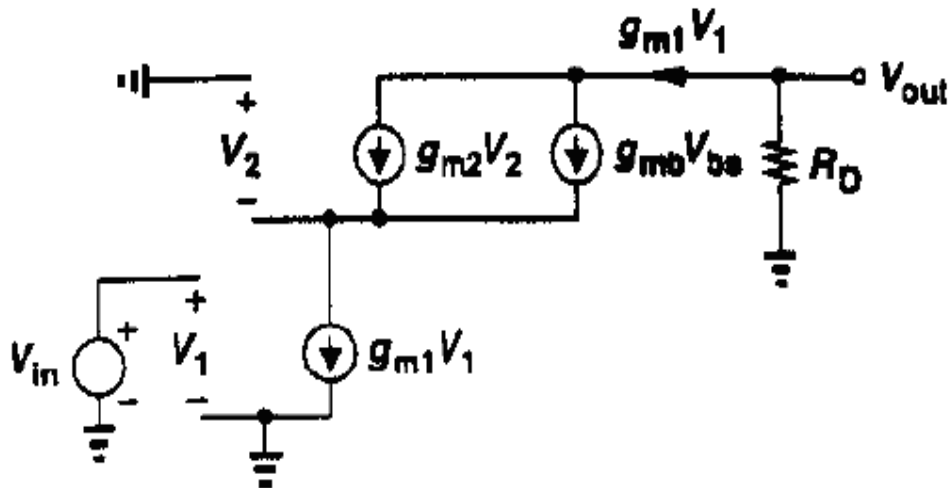

Fig.5. Small signal equivalent circuit of cascode circuit

An important property of the cascode topology is its high output impedance. From Fig.5 the calculation of R_{out} can be made with degeneration resistor equal to r_{o1} . Thus

$$R_{out} = [1 + (g_{m2} + g_{mb2}) r_{o2}]r_{o1} + r_{o2}. \quad (11)$$

3.2 Shielding property to reduce the mismatch

It is the property by which the cascode transistor structure shields the input devices from voltage variations at the output. It could be proved with the mathematical analysis as follows. Consider two identical NMOS transistors used as a constant current sources as

shown in Fig.6. However due to the internal circuitry of the analog system, V_x is higher than V_y by ΔV . The I_{D1} and I_{D2} is calculated by considering the channel length modulation.

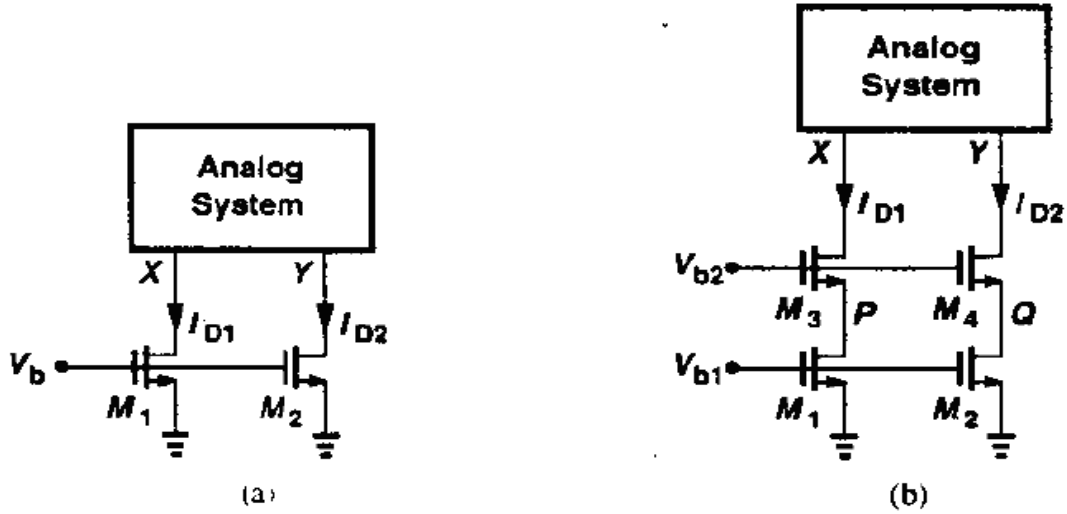

Fig.6. Cascode reduces the mismatch

$$\begin{aligned} I_{D1} - I_{D2} &= \frac{1}{2} [\mu_n C_{ox} W/L (V_b - V_{th})^2 (\lambda V_{DS1} - \lambda V_{DS2})] \\ &= \frac{1}{2} [\mu_n C_{ox} W/L (V_b - V_{th})^2 (\lambda \Delta V)] \end{aligned} \quad (12)$$

As depicted in Fig.7 the change in the applied voltage to the drain affects less at the node V_{RS} as shown by the equivalent circuit of CS with source degeneration resistor.

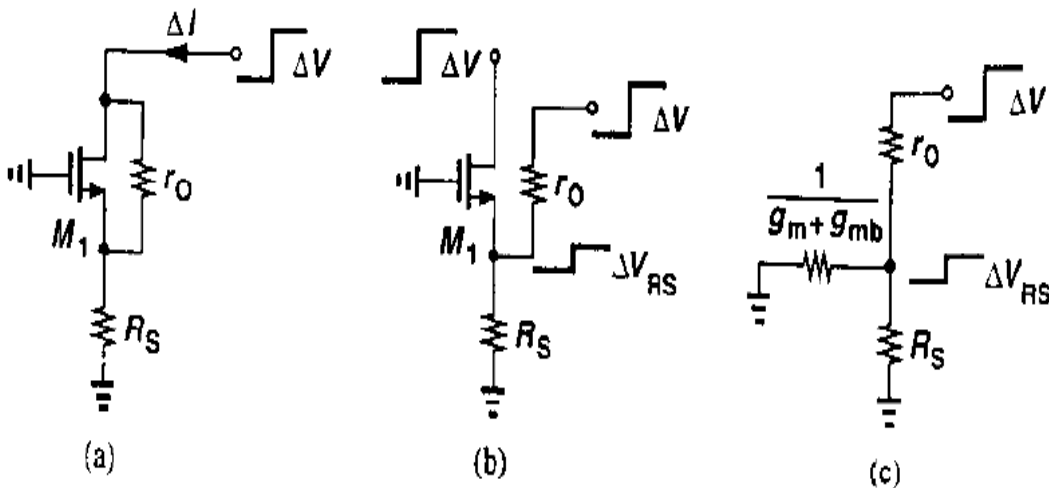

Fig.7. Equivalent circuits

$$\begin{aligned} \Delta V_{PQ} &= \Delta V [r_{O1} / \{ [1 + (g_{m3} + g_{mb3}) r_{O3}] r_{O1} + r_{O3} \}] \\ &\approx \Delta V / [(g_{m3} + g_{mb3}) r_{O3}] \end{aligned} \quad (13)$$

$$I_{D1} - I_{D2} = \frac{1}{2} [\mu_n C_{ox} W/L (V_b - V_{th})^2 (\lambda \Delta V / (g_{m3} + g_{mb3}) r_{O3})] \quad (14)$$

In other words, cascading reduces the mismatch between I_{D1} and I_{D2} by $(g_{m3}+g_{mb3})r_{o3}$. The cascading reduces the effect of V_x and V_y upon I_{D1} and I_{D2} respectively [13]. The difference ΔV between V_x and V_y translates to a difference ΔV_{PQ} between P and Q equal to

$$\begin{aligned} \Delta V_{PQ} &= \Delta V [r_{o1} / [1 + (g_{m3}+g_{mb3}) r_{o3}] r_{o1} + r_{o3}] \\ &\approx \Delta V / (g_{m3}+g_{mb3}) r_{o3} \end{aligned} \quad (15)$$

$$I_{D1} - I_{D2} = \frac{1}{2} [\mu_n C_{ox} W/L (V_b - V_{th})^2 (\lambda \Delta V / (g_{m3}+g_{mb3}) r_{o3})] \quad (16)$$

This proves that the cascading reduces the mismatch between I_{D1} and I_{D2} by a factor $(g_{m3}+g_{mb3})r_{o3}$. Using the idea of cascode for building a circuit with reduced noise and high gain for analog applications, the proposed circuit in Fig.8 is being developed in which the NM_2 act as the diode connected structure and it is permanently biased in saturation and it provide the cascode effect on the input MOS transistor NM_0 . As per the earlier mathematical analysis being made it proves that it should provide high gain and high immunity against the noise

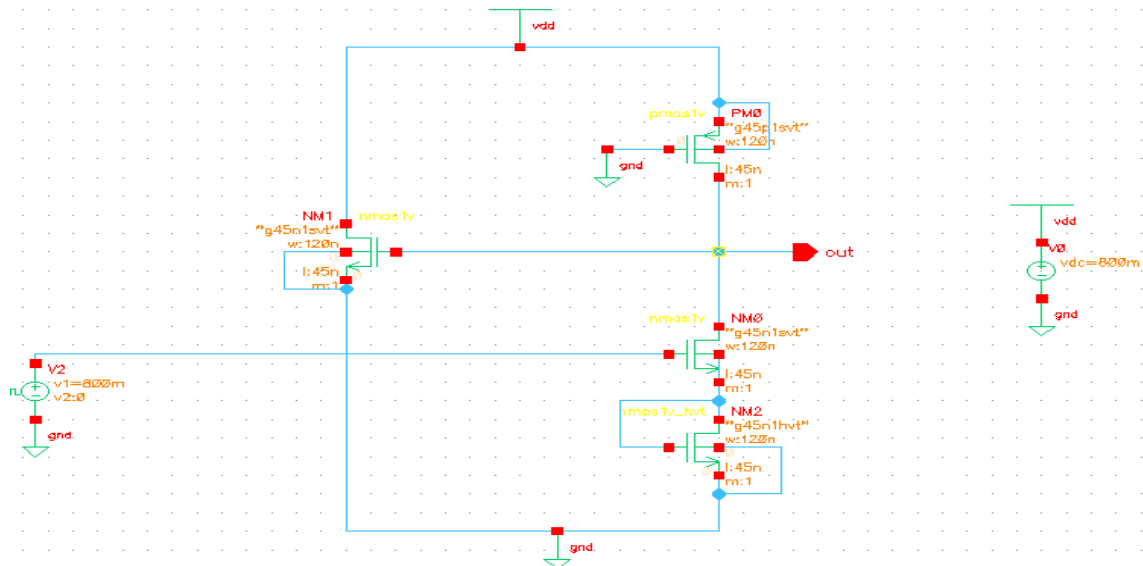

Fig.8. Proposed Highly Stable Current Balanced Logic (HCBL)

3.3 Noise Immune Digital Modified Dynamic Logic

Normally Dynamic logic has the advantage of reducing the power to a great extends just because of its structure. It basically produces the least amount of transitions at the output node and thereby reduces the switching activity and subsequently reduces the power. It works in two phase of operation namely pre-charge and evaluation phase. This actually reduces the switching at the output node [14]. The pass transistor NM_7 connecting the output node to NMOS junction node will act as a bridging capacitor between two points and there by output node charge are used for charging the intermediate NMOS nodes so that the evaluation process speed increases and also the charge leakage in the output node is reused for charging

[15-16] the internal nodes, this will reduce the power consumption to a great extent. The circuit proposed in Fig.9 is used for noise immune low power high speed logic which could be used for many digital applications.

4. Simulation Results

The proposed circuits are constructed using cadence Analog Design Environment (ADE) and the various simulations like Transient, AC and DC analysis are made on the proposed circuits. The parameters considered for simulation are Transistor count, Noise, Delay, Frequency, Bandwidth and Power The proposed Highly stable Current Balanced Logic (HCBL) is simulated for a frequency response of about 10 GHz and the simulated response is shown in Fig .10. The proposed Noise immune Dynamic circuit is constructed as inverter and 3 input NOR gate.

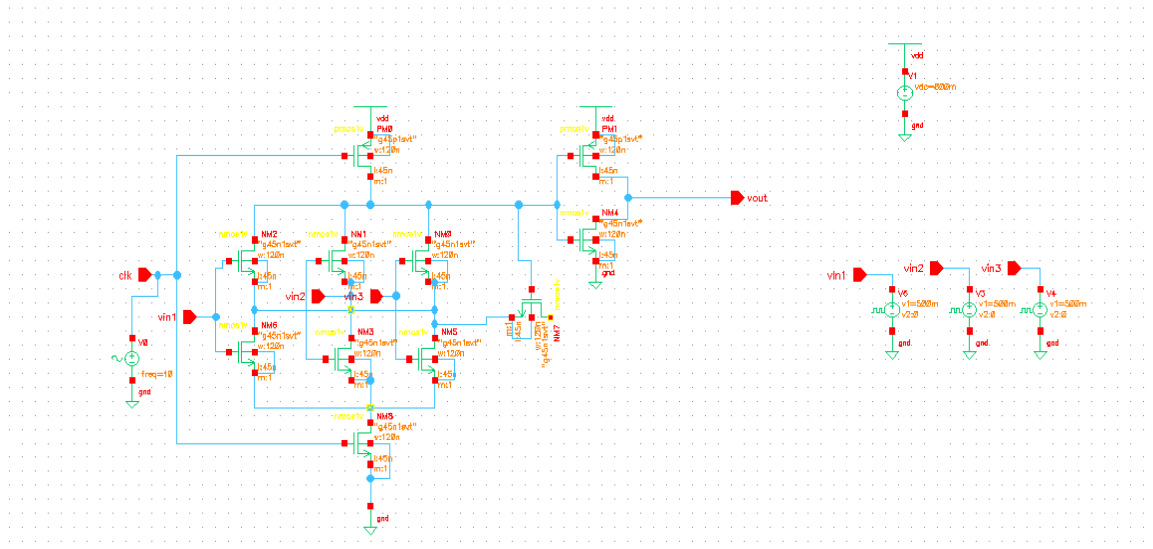

Fig.9. Noise immune Dynamic circuit

The same circuit is simulated for its functional verification using Spectre with 45nm GPDK technology files. The timing calculation (delay) was made between input and output of the proposed circuit and they have been tabulated in Table: 1. Fig.11 shows the delay calculation of the proposed circuit in dynamic logic. The power consumption of the circuit obtained by integrating the current over the whole cycle multiplied with the supply voltage and the same is tabulated in Table: 1. The Noise response of the proposed circuit is simulated for different frequency range. Proposed HCBL shows the $161.5 \text{ V}^2/\text{Hz}$ for a frequency band of 10^6 Hz and proposed dynamic logic shows $12.7 \text{ V}^2/\text{Hz}$ for a frequency band of 10^6 Hz and the same has been shown in Fig.12 (a) and (b) respectively. The delay measured with the proposed circuits is one half compared with the CBL techniques and the bandwidth has been

increased by 100 Hz. Also the simulation results tabulated in the Table 1 shows that the power consumption has been reduced multi-fold for the proposed circuits

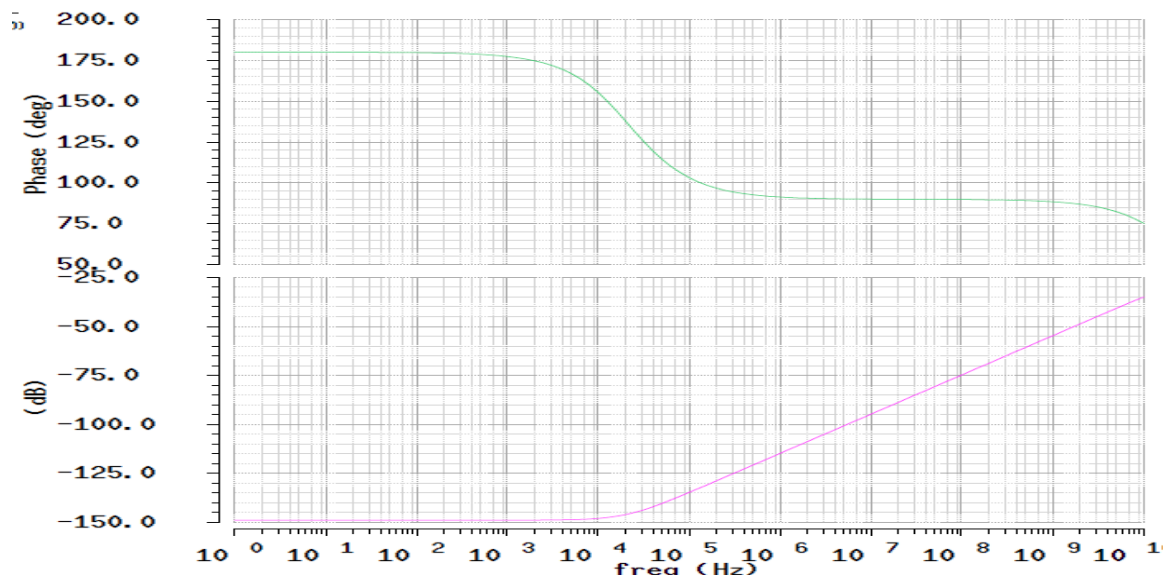

Fig.10. (a) Existing CBL Design

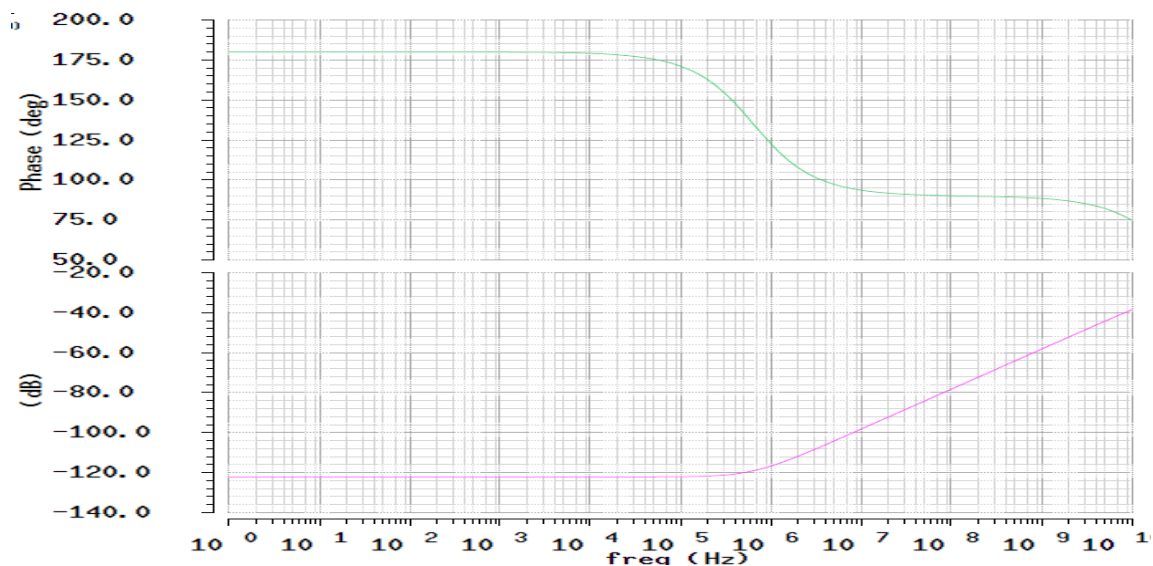

Fig.10. (b) Proposed Highly stable Current Balanced Logic

Table. 1 Comparison table of different parameters with the proposed logic

Logic family	Type of Logic	No. of Transistors	Noise (V ² /Hz)	Delay (ps)	Frequency (GHz)	Bandwidth (Hz)	Power (μW)
CBL	NMOS Inverter	3	NA	16	62.5	10 ⁴	5.512
Proposed (HCBL) Logic	NMOS Inverter	4	161.5	8	125	10 ⁶	0.013
Proposed Dynamic Logic	MOS Inverter	4	12.7	7	125	10 ⁶	0.009

NA- Not Available

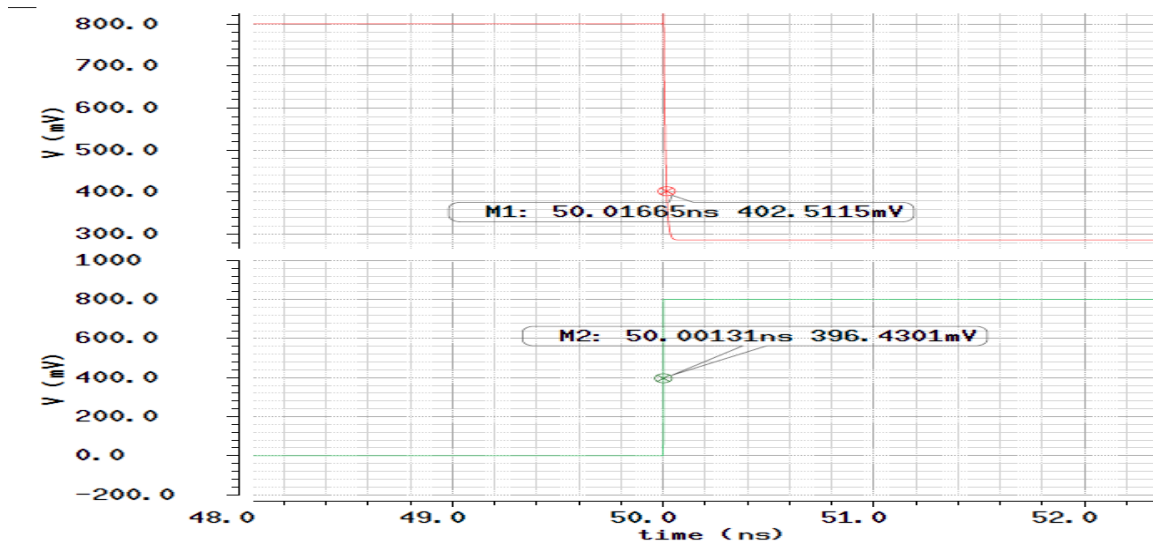

Fig.11. Timing Calculation for proposed dynamic logic

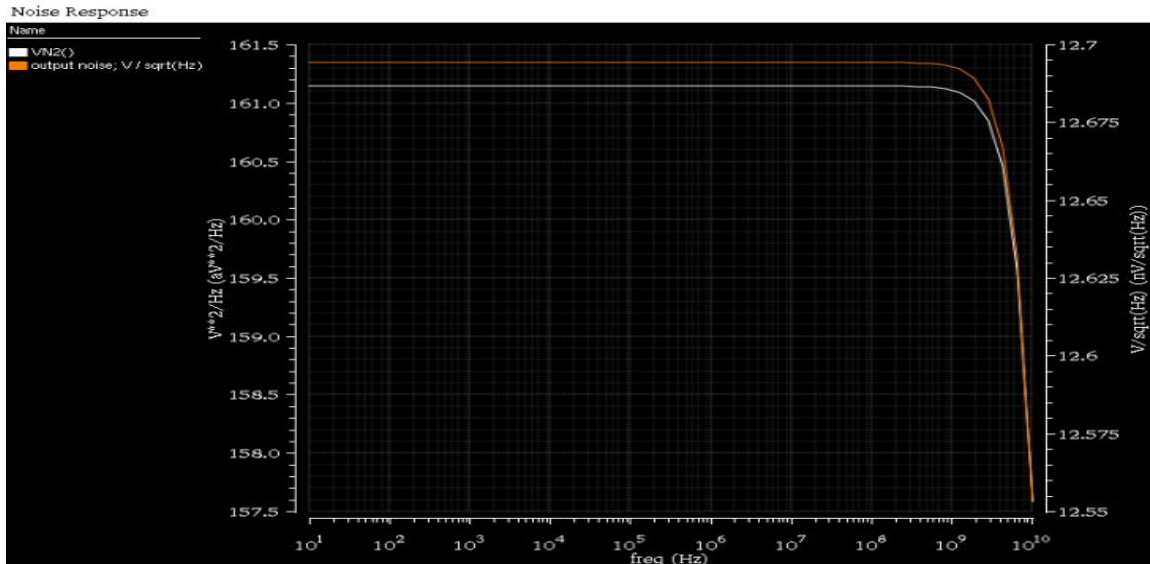

Fig.12. (a) Proposed HCBL

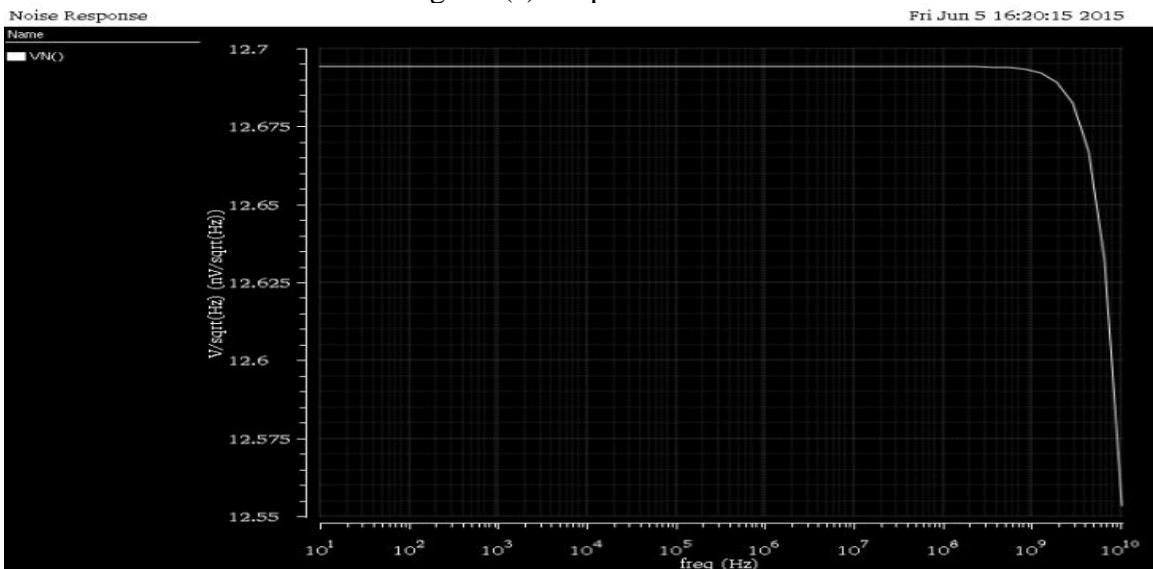

Fig.12. (b) Proposed Dynamic logic

Conclusion

A noise tolerant digital and analog circuit is being proposed, constructed and simulated. The HCBL provides fewer mismatches and high gain for analog circuits and the robustness towards noise is high. The digital dynamic logic provides high noise stability with high speed and less power. The Noise response of the proposed circuit is simulated for different frequency range. Proposed HCBL shows the $161.5 \text{ V}^2/\text{Hz}$ for a frequency band of 10^6 Hz and proposed dynamic logic shows $12.7 \text{ V}^2/\text{Hz}$ for a frequency band of 10^6 Hz . The simulation results shows that the power consumption has been reduced multi-fold and the bandwidth has been increased by 100 Hz and the delay is reduced by 50%. These suggest the use of the circuits for both analog and digital system building with reduction in power consumption. These circuits also provides better model for noise in CMOS circuits, which increases the reliability of the mixed design

References

1. D. J. Allstot, S. Kiaei and R. H. Zele, "Analog logic techniques steer around the noise," *IEEE Circuits Devices Mag.*, vol. 9, pp. 18–21, Sept.1993.
2. H.T. Ng and D. J. Allstot, "CMOS current steering logic for low voltage mixed-signal integrated circuits," *IEEE Trans. VLSI Syst.*, vol.5, pp. 301–308, Sept. 1997.
3. H. Sakamoto and L. Forbes, "Grounded load complementary FET circuits: Sceptre analysis," *IEEE J. Solid-State Circuits*, vol. 8, pp.282–284, Aug. 1973.
4. A. Sedra and K. Smith, *Microelectronic Circuits*, 4th ed. Oxford, U.K:Oxford Univ. Press, 1998.
5. The International Technology Roadmap for Semiconductors: 1999 Edition, URL: <http://www.itr~.net/1999SIARoadmap/Home.htm>.
6. A. Chandrakasan and R. W. Brodersen, "Minimizing power consumption in digital CMOS circuits," *Proceedings of the IEEE*, vol. 83, no. 4, pp. 498-523, Apr 1995.
7. L. Wang and N. R. Shanbhag, "Noise-tolerant dynamic circuit design," *Proc. of IEEE Intl. Symposium on Circuits and Systems*, pp. 549-552, May/June 1999.
8. G. Balamurugan and N. R. Shanbhag, "Energy-efficient dynamic circuit design in the presence of crosstalk noise," *Proceedings of International Symposium on Low-Power Electronics and Design*, San Diego, 1999.
9. N. R. Shanbhag, "A mathematical basis for power-reduction in digital VLSI systems," *IEEE Trans. Circuits Systems*, vol. 44, No.11, Nov 1997.

10. R. H. Krambeck, C. M. Lee and H.-F.S. Law, "High-speed 'compact circuits with CMOS," *IEEE J. Solid-state Circuits*, vol. 17, pp. 614-619, June 1982.
11. J. J. Covino, "Dynamic CMOS circuits with noise immunity," 'U.S. Patent 5650733, 1997.
12. G. P. D'Souza, "Dynamic logic circuit with reduced charge leakage," U.S. Patent 5483181, 1996.44, pp. 935-951, Nov 1997.
13. C. E. Shannon, "A mathematical theory of communication," *Bell System Technical Journal*, vol. 27, part I, pp. 379-423, July 1948.
14. R. Gonzales, B. M. Gordon and M. A. Horowitz, "Supply and threshold voltage scaling for low power CMOS," *IEEE Journal on Solid-State Circuits*, vol. 32, pp. 1201-1216, Aug. 1997
15. K. Nepal, R. I. Bahar, J. Mundy, W. R. Patterson and A. Zaslavsky, "Techniques for designing noise-tolerant multi-level combinational circuits," in Proc. Des. Autom. Test Eur., pp. 576– 581, Mar. 2007.
16. I Chyn Wey, You-Gang Chen and An-Yen Wn, "Design and analysis of Isolated Noise-Tolerant (INT) Technique in Dynamic CMOS Circuits", *IEEE Transactions on Very Large Scale Integration (VLSI) Systems*, vol 16, No. 12, pp. 1708-1712, Dec 2008.
17. Frustaci F, Corsonello P, Perri S and Cocorullo G, "High-performance Noise-tolerant circuit techniques for CMOS dynamic logic", *IET Transaction of Circuits, Devices and Systems*, vol 2, No.6, pp. 573- 548, Dec 2008.
18. Tezaswi Raja, Vishwani D. Agrawal and Michael L. Bushnell, "Variable Input Delay CMOS Logic for Low Power Design" *IEEE Transactions on Very Large Scale Integration (VLSI) Systems*, vol. 17, No.10, pp. 1534-1545, Oct 2009.
19. Ajay Taparia, Bhaskar Banerjee and T. R. Viswanathan, "CS-CMOS: A Low-Noise Logic Family for Mixed Signal SoCs", *IEEE Transactions on Very Large Scale Integration (VLSI) Systems*, vol.19, Issue 12, pp. 2141-2148, Nov 2012.
20. Sandeep Sangwan, Jyoti Kedia and Deepak Kedia, "A Comparative Analysis of different CMOS Logic Design Techniques for Low Power and High Speed", *International Journal of Advanced Research in Electrical, Electronics and Instrumentation Engineering*, vol. 2, No.10, Oct 2013.
21. Araga Y, Nagata M, Van der Plas G and Marchal P, "Measurements and Analysis of Substrate Noise Coupling in TSV-Based 3-D Integrated Circuits", *IEEE Transaction*

on Components, Packing and Manufacturing Technology, vol. 4, No. 6, pp. 1026-1037, Apr 2014.

22. Bo Zhao and Huazhong Yang, "Supply-Noise Interactions Among Submodules Inside a Charge-Pump PLL", *IEEE Transactions on Very Large Scale Integration (VLSI) Systems*, vol. 23, No.4, pp.771-775, Apr 2015.