

Line to Line Short Circuit Fault Diagnosis in Photo-Voltaic Array based Microgrid System

*T. K. Das, **S. Chattopadhyay, ***A. Das

*Department of Electrical Engineering, GKCIET, West Bengal, India

(p_tapash_das@yahoo.co.in)

** Department of Electrical Engineering, GKCIET, West Bengal, India,

(surajitchattopadhyay@gmail.com)

*** Department of Electrical Engineering, Jadavpur University, West Bengal, India,

(adas_ee_ju@gmail.com)

Abstract

Microgrid system has been modelled where, three phase inverter has been fed by a number of solar photo voltaic arrays. The output of the inverter has been connected with a three phase step-up transformer coupled with high-voltage grid bus and high-voltage load bus. Load bus line to line short circuit fault has been assessed from inverter terminal. Output currents of the inverter has been captured and analyzed. DC components and Total Harmonics Distortion of line currents have been monitored both at normal condition and fault condition. Then, wavelet decomposition is performed on line currents at different fault conditions. Detailed and approximate coefficients at different decomposition levels have been determined and nature of these coefficients have been assessed by their skewness values. Comparative study has been carried out between normal and fault conditions. Distinct features have been extracted for diagnosis of line to line fault near load end from low-voltage inverter output terminals.

Keywords

Discrete wavelet transforms (DWT), Line to line fault, Skewness, Total harmonics distortion.

Glossary

DWT- Discreet Wavelet Transform
FFT- First Fourier Transform
LL- Line to Line Fault
PV-Photo Voltaic
SA- Skewness of Approximate Co-efficient
SD- Skewness of Detail Co-efficient
THD- Third Harmonics Distortion

1. Introduction

With the increase of electric power demand, use of non-conventional resources has increased to a great extent. Among different energy resources solar power has become very popular which gives green power. With the increase of use of solar power, the concept of microgrid system is developing. Such microgrid connects nature friendly energy resources like solar power with conventional grid system and also feeds power to utility system. A lot of research work is going on to study performance of microgrid [1] – [4].

Pan Duan et al (2010) performed detailed analysis on [1] open-switch fault diagnosis and system reconfiguration techniques used in a microgrid where a special anti-false-alarm diagnosis method was proposed to detect the locations and styles of open switch faults efficiently. The integration of Z-source breakers into zonal DC ship power system microgrids [2] was presented by Atif Maqsood et al (2016) where a new fault detection algorithm has been demonstrated to track the path of the fault current for shunt faults created at various locations in dc microgrid. Yuanyuan Wang et al (2016) introduced faulty feeder detection of single phase-earth fault using Grey relation degree in resonant grounding system applicable for at least three or more feeders system where different simulation techniques have been carried out to confirm reliability and accuracy of the scheme [3]. Ashika Gururani et al (2016) introduced microgrid protection using Hilbert–Huang transform based-differential scheme, where an experimental model of microgrid has been developed using PSCAD for fault diagnosis [4]. Jason Poon et al (2016) performed detailed analysis on model-based fault detection and identification for switching power converters, where the FDI algorithm was demonstrated for enhancing identification of faults in dc distribution of microgrid network [5]. O. V. Gnana Swathika et al introduced a new Prims-Aided Dijkstra algorithm for adaptive protection in microgrid, where a central protection center (CPC) has been installed to monitor continuously, detect fault and its location [6]. A new protection scheme for multi-bus DC power systems using an event classification approach has been introduced by Mustafa Farhadi and Osama A. Mohammed (2016), where, less data is transferred

compared to other protection scheme and by maintaining continuous supply to the loads, detection of fault types, faulty part isolation and quick restoration of the system have been observed [7]. Leandro de Marchi Pintos et al (2016) performed detailed analysis of directional over current relay without voltage reference in microgrids. In this attempt, the feasibility and application of the directional protection scheme in distribution network by only current measurement has been demonstrated [8]. Chen et al (2014) has introduced an analytical adequacy evaluation method for distribution networks considering protection strategies and distributed generators for enhancing the efficiency and reliability calculation, fault isolation and supply restoration [9].

M. Sabarimalai Manikandan et al (2014) proposed a new technique for detection and classification of power quality disturbances using sparse signal decomposition on hybrid dictionaries, where, PQ disturbances using a sparse signal decomposition (SSD) on over complete hybrid dictionary (OHD) matrix used in microgrid has been presented [10]. Yun Liu et al (2014) modeled a special power control strategy for photovoltaic system based on the Newton quadratic interpolation to increase the economic benefits, where many simulation works have been carried out in maximum power point tracking (MPPT) mode of solar photovoltaic [11]. The signature-coordinated digital multirelay protection for microgrid systems [12] has been introduced by S. A. Saleh (2013), where, a new fault detection techniques based on the wavelet packet transform (WPT) in microgrid were performed in detail. S Kar et al (2014) described the time-frequency transform-based differential scheme for microgrid protection [13] for protection against various symmetrical and unsymmetrical faults. Ali Kasem Alaboudy et al (2013) analyzed in detail, simple control strategy for inverter-based distributed generator to enhance microgrid stability in the presence of induction motor loads, where, many transient control mode (TCM) based computer simulations were performed in Matlab environment to demonstrate microgrid stability and fault duration [14].

Yasser Abdel-Rady Ibrahim Mohamed et al (2011) described in detail the Seamless Formation and Robust Control of distributed generation microgrids via direct voltage control and optimized dynamic power sharing, where the results of both theoretical and experimental analysis have been demonstrated [15]. The unsymmetrical short-circuit fault analysis for weakly meshed distribution systems [16] have been developed by Jen-Hao Teng (2009). A novel fault-locator system, algorithm, principle and practical implementation has been introduced [17] by M A. Mirzai et al (2009) to reduce the differences between the calculated and actual fault location. Jung-Uk Lim et al (2006) performed detailed analysis on improvement of the voltage difference method to detect arcing faults within unfused grounded-wye 22.9-kV shunt capacitor bank [18],

where a new algorithm and Fast Fourier Transform (FFT) analysis for detecting the ground faults over the existing methods have clearly been demonstrated. Many current signature-based fault diagnosis tools [19] – [20] have also been introduced.

However, very few works are observed which deal with harmonics assessment-based diagnosis of fault at HV bus from the low voltage inverter output bus. This has motivated others to analyze inverter output signals for assessment of fault at high-voltage bus near load end. Signals have been captured and then DC components & harmonic distortion have been determined. At last, wavelet decomposition is performed and signals are analyzed by statistical parameter “skewness” [21]. A comparative study has been carried out between normal and fault conditions.

2. Modeling of Microgrid

In this work 200KW microgrid system has been modeled as shown in Fig.1, where parallel combination of PV arrays has been connected with three phase inverter. In each PV array 48 strings have been used. Each string has five series connected modules. Each module can deliver 310-Watt maximum power and has 60 V open circuit voltage, 5.5 A short circuit current, “-0.26” % per degree centigrade temperature co-efficient, 0.95 diode ideality factor, 420 ohms shunt resistance and 0.42 ohms series resistance.

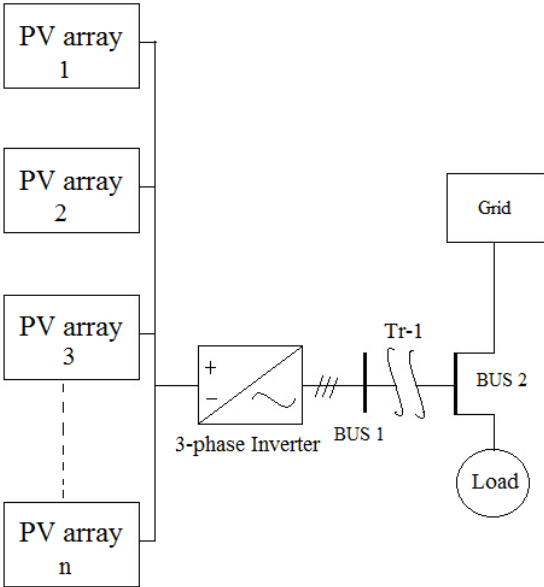

Fig. 1 Single Line Diagram of 400KW PV Array Based Microgrid

PV arrays are connected with dc to ac three-phase inverter. In inverter, average model of voltage source converter with three bridge arms has been used. Phase to neutral voltage of

inverter is 220V to 260V, 60 Hz. The inverter output is connected with 200KVA, 260/25KV, 60 Hz star-delta transformer. Transformer output bus is connected with two 25 KV buses: one is connected with conventional grid and another is feeding power to local load system. The grid has the capacity of 47MVA power at a voltage level of 25KV and the grid power is maintained by 2500MVA, 20KV generating unit through 47MVA, 120KV/25KV transformer.

Fault has been created in the bus connected with load and data has been captured from inverter output terminals for monitoring.

3. DC Components

From the line currents captured at inverter terminals, DC component present in the phase or line currents have been measured. DC component obtained at normal condition and line to line (LL) short circuit faults among phases A-B, B-C, C-A respectively has been presented in Table 1. At normal condition 60% load was connected with the inverter. From Table 1 it is observed that magnitudes of DC components are changing from normal condition to fault condition. However, DC components of phase A, phase B and phase C are different and nature of their changes are also different. Therefore, identification of faulty phases from DC components becomes difficult.

Tab. 1. DC Components at Normal and Fault Conditions

Phase	Normal (A)	LL in AB (A)	LL in BC (A)	LL in CA (A)
DC component in A	0.2625	2.223	14.29	20.24
DC component in B	24.3	8.134	29.25	6.825
DC component in C	24.04	10.36	14.96	27.06

4. Total Harmonics Distortion

From the line currents captured at inverter terminals, Total Harmonics Distortion (THD) present in the phase or line currents have been measured. THD obtained at line to line (LL) short circuit faults among phases A-B, B-C, C-A respectively has been presented in Table 2. And nature of variation has been shown in Fig. 2.

Tab. 2. Total Harmonics Distortion at Line to Line short-circuit fault

THD	LL in AB	LL in BC	LL in CA
THD in A (%)	23.18	18.73	24.68
THD in B (%)	21.74	19.67	17.98

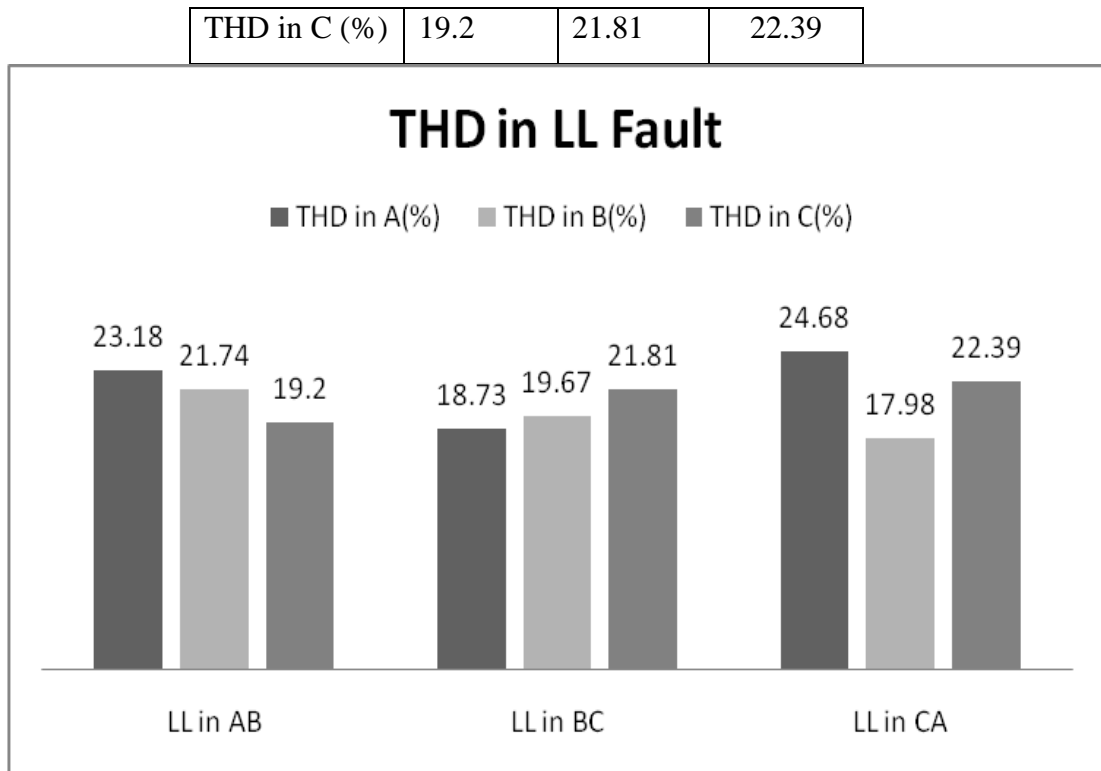

Fig. 2. Total Harmonics Distortion (THD) at Line to Line short-circuit fault

It is observed that THD is changing at different fault conditions. For line to line short circuit fault in phase A and phase B, THD is lowest at phase C. For line to line short circuit fault in phase B and phase C, THD is lowest at phase A. For line to line short circuit fault in phase C and phase A, THD is minimum at phase B. Thus, the phase showing minimum THD is found healthy indicating that the fault has occurred in other two phases.

5. Wavelet Decomposition of Inverter Output Current

Discrete wavelet transform is an effective tool for the study of non-stationary waveforms collected in discrete manner. Wavelet decomposition based statistical parameters can well describe the behavior of non-stationary waveforms. The DWT parameters have been used in detection of transmission line faults in the presence of solar PV generation [22], partial shading fault diagnosis in PV system [23] and for analysis of grid-connected photovoltaic systems [24]. Approximate and detailed co-efficients have been determined and their skewness values have been calculated at different fault conditions. In this work, wavelet decomposition is performed on the line currents at inverter output terminals. As the signals are captured in discrete manner, Discrete Wavelet Transform (DWT) is used, decomposition is performed up to DWT level nine and Skewness [21] values are determined for analysis. Skewness [21] values for approximate co-

efficients (SA) of phase A for normal condition and LL faults in phases A-B, B-C & C-A respectively have been presented in Table 3.

Tab. 3. SA at Different Line to Line fault conditions

SA of Ia_N	SA of ia_ab	SA of ia_bc	SA of ia_ca
-0.020	-0.028	-0.051	-0.020
-0.020	-0.028	-0.051	-0.020
-0.020	-0.028	-0.051	-0.020
-0.0202	-0.027	-0.050	-0.020
-0.021	-0.023	-0.044	-0.021
-0.132	-0.068	-0.068	-0.132
0.079	-0.283	-0.253	-0.395
-0.262	-0.881	-0.484	-0.896
-2.867	-3.833	-3.414	-3.843

Variation of skewness of approximate co-efficient with respect different DWT levels has been shown in Fig. 3.

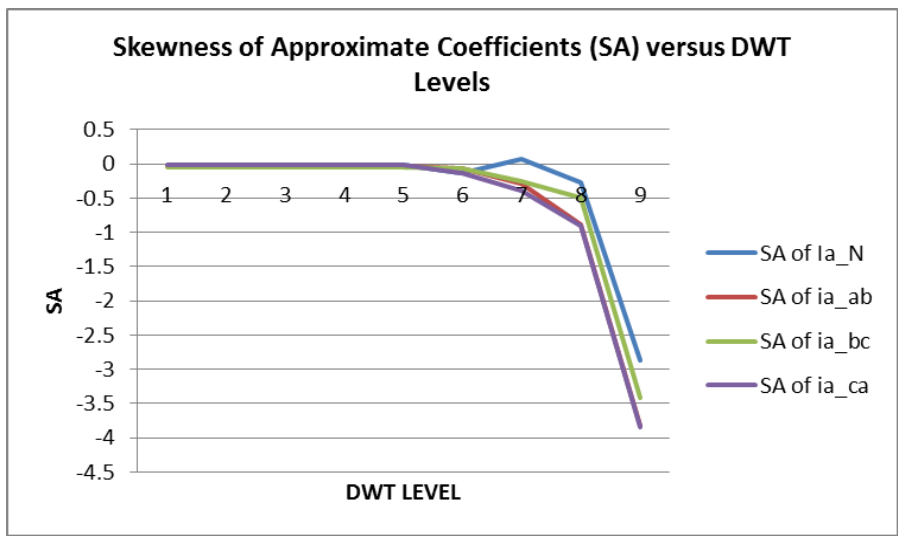

Fig. 3 SA versus DWT Levels

It shows that SA is different for different fault conditions at DWT level eight and nine. At 8th and 9th level SA is lowest during healthy condition. At these levels SA decreases during line to line short circuit fault and is minimum when line to line short circuit fault occurs in between phases A & B and phase C & A; in both cases Phase A is faulty phase. When fault occurs in between phase B & C and phase A remains healthy, SA at 8th and 9th level is less than that of

normal but greater than SA when Phase A becomes faulty. Thus monitoring of SA at DWT level nine may be an effective tool for identification of faulty phases.

Skewness values for detailed coefficients (SD) of phase A for normal condition and LL faults in phases A-B, B-C & C-A, respectively, have been presented in Table 4.

Tab. 4. SD at Different Line to Line fault conditions

SD of Ia_N	SD of ia_ab	SD of ia_bc	SD of ia_ca
-1.612	-8.799	-6.759	-8.799
-0.102	-0.996	-0.359	-0.756
0.035	0.240	-0.016	0.056
0.062	0.748	0.575	0.225
-0.097	0.129	0.039	-0.102
-0.038	-0.027	-0.048	-0.038
-0.027	-0.004	-0.004	-0.027
0.033	0.073	-0.091	0.032
0.416	0.271	0.061	0.416

Variation of skewness of detailed co-efficient with respect different DWT levels has been shown in Fig. 4.

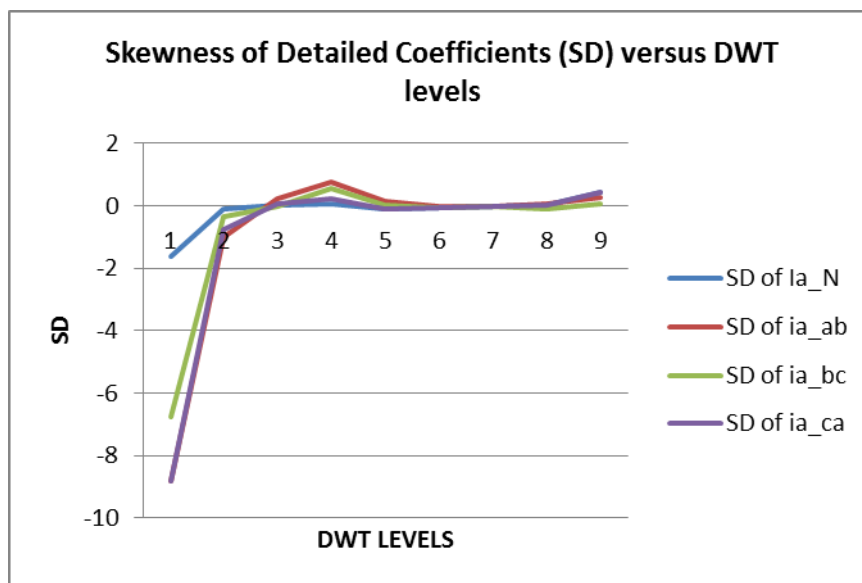

Fig. 4 SD versus DWT Levels

It shows that SD is different for different fault conditions at 1st level of DWT and then becomes equal and almost constant. At 1st level, SD is maximum during healthy condition i.e. when all phases A, B and C remain healthy. At first level SD decreases during line to line short circuit fault and is minimum when line to line short circuit fault occurs in between phases A & B and phase C & A; in both cases Phase A is faulty phase. When fault occurs in between phase B & C and phase A remains healthy, SD at 1st is less than that of normal but greater than SD when Phase A becomes faulty. Thus, monitoring of SD at 1st DWT level may be an effective tool for identification of faulty phases.

6. Discussion

In this work, at normal and line to line fault condition DC component, Total Harmonic Distortion and Skewness values have been assessed. The summary of the observations has been presented in Table 5.

Tab. 5. Summary of the Observations Made on Normal and Line to Line Fault Condition

Condition	DC components	THD	Effect in phase A	
			SA	SD
Normal	No specific relation of pattern found	Almost same in all phases	High at 8 th and 9 th level	High at 1 st level
LL fault in Phases A & B		Lowest in phase C	Low at 8 th and 9 th level	Low at 1 st level
LL fault in Phases B & C		Lowest in phase A	Medium at 8 th and 9 th level	Medium at 1 st level
LL fault in Phases C & A		Lowest in phase B	Low at 8 th and 9 th level	Low at 1 st level
Inference	No decision can be made	Lowest value indicates healthy phase referring other two faulty	Low indicates that the phase is faulty	Low indicates that the phase is faulty

Comparative analysis has been made using the observations of section 4 and 5. DC component is found not suitable for decision making. During fault, the phase showing lowest THD value refers to healthy phase. For SA, 8th and 9th level is suitable for fault detection; lowest

value is indicating fault condition. For SD, 1st level is suitable for fault detection; lowest value is indicating fault condition.

In other works, described in section 1, many attempts are found for detection and classification of fault which was mainly deals with magnitude and phase comparison. Most of them lack in giving information of the non-stationary behavior of the waveforms and harmonics related information. This limitation has been overcome by this work which gives measurement of harmonic distortion and Skewness values along with detection of fault.

Conclusion

In this paper, solar PV unit has been connected through a microgrid consisting of an inverter and step up transformer with conventional grid and local electrical load unit. Signals from the output of inverter unit have been used for assessment of load bus line to line short circuit fault. Output currents of the inverter has been captured and analyzed; DC components and Total harmonics distortion of line currents are derived both at normal condition and fault condition. Then, detailed and approximate coefficients at different discrete wavelet decomposition levels have been compared between normal and fault conditions by their skewness values. It is found that DC component is not suitable for fault analysis. However, changes in THD value can be used for fault diagnosis. Among different decomposition level 8th and 9th levels for SA and 1st level for SD are found suitable for fault diagnosis. The method can also be extended for diagnosis of faults in other part of the microgrid.

References

1. P. Duan, K. Xie, L. Zhang, X. Rong, Open-switch fault diagnosis and system reconfiguration of doubly fed wind power converter used in a microgrid, 2010, IEEE Transactions on Power Electronics, Vol. 26, no. 3, pp. 816-821.
 2. A. Maqsood, K.A. Corzine, Integration of z-source breakers into zonal DC Ship power system microgrids, IEEE Journal of Emerging and Selected Topics in Power Electronics, 2016, Vol. 5, no. 1, pp. 269-277.
 3. Y. Wang, Y. Huang, X. Zeng, G. Wei, J. Zhou, Faulty feeder detection of single phase-earth fault using grey relation degree in resonant grounding system, 2016, IEEE Transactions on Power Delivery, Vol. 32, no. 1, pp. 55-61.
- A. G.S.R. Mohanty, J.C. Mohanta, Microgrid protection using Hilbert–Huang transform based-differential scheme, 2016, IET Generation, Transmission & Distribution, Vol. 10, no. 15, pp. 3707-3716.

4. J. Poon, P. Jain, I.C. Konstantakopoulos, C. Spanos, S.K. Panda, S.R. Sanders, Model-based fault detection and identification for switching power converters, 2016, IEEE Transactions on Power Electronics, Vol. 32, no. 2, pp. 1419-1430.
5. V. Gnana Swathika, S. Hemamalini, Prims-aided dijkstra algorithm for adaptive protection in microgrids, 2016, IEEE Journal of Emerging and Selected Topics in Power Electronics, Vol. 4, no. 4, pp. 1279-1286.
6. M. Farhadi, O.A. Mohammed, A new protection scheme for multi-bus dc power systems using an event classification approach, 2016, IEEE Transactions on Industry Applications, Vol. 52, no. 4, pp. 2834-2842.
7. L. de Marchi Pintos, M. Moreto, J.G. Rolim, Applicability analysis of directional overcurrent relay without voltage reference in microgrids, 2016, IEEE Latin America Transactions, Vol. 14, no. 2, pp. 687-693.
8. C. Chen, W. Wu, B. Zhang, C. Singh, An analytical adequacy evaluation method for distribution networks considering protection strategies and distributed generators, 2014, IEEE Transactions on Power Delivery, Vol. 30, no. 3, pp. 1392-1400.
9. M.S. Manikandan, S.R. Samantaray, I. Kamwa, Detection and classification of power quality disturbances using sparse signal decomposition on hybrid dictionaries, 2014, IEEE Transactions on Instrumentation and Measurement, Vol. 64, no. 1, pp. 27-38.
10. Y. Liu, H. Xin, Z. Wang, T. Yang, Power control strategy for photovoltaic system based on the Newton quadratic interpolation, 2014, IET Renewable Power Generation, Vol. 8, no. 6, pp. 611-620.
11. S.A. Saleh, Signature-coordinated digital multirelay protection for microgrid systems, 2013, IEEE Transactions on Power Electronics, Vol. 29, no. 9, pp. 4614-4623.
12. S. Kar, S.R. Samantaray, Time-frequency transform-based differential scheme for microgrid protection, 2014, IET Generation, Transmission & Distribution, Vol. 8, no. 2, pp. 310-320.
13. A.K. Alaboudy, H. Zeineldin, J. Kirtley, Simple control strategy for inverter-based distributed generator to enhance microgrid stability in the presence of induction motor loads, 2013, IET Generation, Transmission & Distribution, Vol. 7, no. 10, pp. 1155-1162.
14. Y.A-R.I. Mohamed, H.H. Zeineldin, M.M.A. Salama, R. Seethapathy, Seamless formation and robust control of distributed generation microgrids via direct voltage control and optimized dynamic power sharing, 2011, IEEE Transactions on Power Electronics, Vol. 27, no. 3, pp. 1283-1294.
15. J.H. Teng, Unsymmetrical short-circuit fault analysis for weakly meshed distribution systems, 2009, IEEE Transactions on Power Systems, Vol. 25, no. 1, pp. 96-105.

16. M.A. Mirzai, A.A. Afzalian, A novel fault-locator system; algorithm, principle and practical implementation, 2009, IEEE Transactions on Power Delivery, Vol. 25, no. 1, pp. 35-46.
17. J.U. Lim, T. Runolfsson, Improvement of the voltage difference method to detect arcing faults within unfused grounded-wye 22.9-kV shunt capacitor bank, 2006, IEEE Transactions on Power Delivery, Vol. 22, no. 1, pp. 95-100.
18. S. Chattopadhyay, S. Karmakar, M. Mitra, S. Sengupta, Loss of phase fault detection of an induction motor, 2011, AMSE Journal Series: Modelling A, vol. 85, no. 2, pp. 18-34.
19. S. Chattopadhyay, S. Karmakar, M. Mitra, S. Sengupta, Radar analysis of stator current concordia for diagnosis of unbalance in mass and cracks in rotor bar of a squirrel cage induction motor, 2012, AMSE Journals, Series: Modelling A, vol. 85, no. 1, pp. 50-61.
20. Chattopadhyaya, S. Chattopadhyay, J.N. Bera, S. Sengupta, Wavelet decomposition-based skewness and kurtosis analysis for assessment of stator current harmonics in a PWM – fed induction motor drive during single phasing condition, 2016, AMSE Journals-2016- Series: Modelling C, Vol. 77, No. 1, pp 28-40.
21. T. Suman, O.P. Mahela, S.R. Ola, Detection of transmission line faults in the presence of solar PV generation using discrete wavelet, 2016, IEEE 7th Power India International Conference (PIICON), Bikaner, India.
22. M. Davarifar; A. Rabhi, A. Hajjaji, E. Kamal, Z. Daneshifar, Partial shading fault diagnosis in PV system with discrete wavelet transform (DWT), 2014, International Conference on Renewable Energy Research and Application (ICRERA), Milwaukee, WI, USA
23. T.M. Cesar, S.P. Pimentel, E.G. Marra, B.P. Alvarenga, Wavelet transform analysis for grid-connected photovoltaic systems, 2017, 6th International Conference on Clean Electrical Power (ICCEP), Santa Margherita Ligure, Italy.