

## Development of energy efficient, cost-optimized transformer with low partial discharges

Dhruvesh Mehta\*, Prasanta Kundu, Anandita Chowdhury

Department of Electrical Engineering, SVNIT, Surat, Gujarat, India

Corresponding Author Email: [dhruveshmehta@gmail.com](mailto:dhruveshmehta@gmail.com)

[https://doi.org/10.18280/mmc\\_a.910205](https://doi.org/10.18280/mmc_a.910205)

### ABSTRACT

**Received:** 23 May 2018

**Accepted:** 30 June 2018

#### Keywords:

*transformer, stray loss, leakage flux, Partial Discharge (PD), energy efficient, Finite Element Method (FEM)*

Escalating Global GDP (Gross Domestic Product) rate and Global Primary energy consumption demand reliable, uninterrupted and adequate power with high transmission efficiency. In the transmission system, Transformers have the highest population with the highest energy efficiency amongst all other electric devices. Transformers practically operate throughout the year at various load conditions. Therefore, the Total losses in transformers are core loss/no-load loss +  $I^2R$  Losses + stray losses (due to the linkage of stray flux in structural parts like core clamping structure, tank, etc). Out of these losses in transformer, Stray loss (undesirable) component is more than 20% of the total load loss. Loss capitalization is an important factor in Transformer owning cost which depends on losses and other parameters. Therefore, reduction of stray losses gives the advantage in lower owning cost as well increase in the transmission line efficiency. The paper presents the use of UDEL (Unimpregnated densified electrical grade laminated) wood as a core clamping structure to reduce stray losses and subsequent reduction in heating effects with further advantage in owning cost of the transformer. Development of 15 MVA, 66/11.55 kV transformer with use of UDEL wood core clamp structure against conventional mild steel core clamp is discussed. Results show that there is a 28.2% reduction of stray loss and 4.5% reduction of total losses using the proposed method. The use of UDEL wood also reduces the partial discharges in magnitude (average 27% reduction) by avoiding magnetic material in the vicinity of high voltage leads and yoke shunts. Structural analysis was also performed using Finite Element Method (FEM) based software to check the suitability of wood core clamp structure under dynamic short circuit test condition. To ascertain the ability of UDEL wood core clamping structure, dynamic short circuit withstand test is conducted at the national laboratory and transformer has successfully withstood the test.

## 1. INTRODUCTION

A transformer is a vital link in the power system to transmit power. Transformers have the highest efficiency amongst all other electric devices which work on the principle of electromagnetic induction. In a typical power distribution network, Loss contribution of the transformer is about 40-50% of the total transmission and distribution losses. Typical values of the transformer efficiencies are in the range of 99% to 99.7% for 25 kVA to 50 MVA (Efficiency values are at 50% of nameplate rated load and at a reference temperature of 75°C). If we considered Total 5000 nos. of installation of 25 kVA transformers with 97% efficiency, and if efficiency is increased by only 1%; yearly 11 million units of electricity could be saved. Therefore, Energy efficient transformers are an important element to reduce transmission and distribution losses [1-2]. Transformer efficiency is mostly described by two elements – magnetic losses/no load loss (hysteresis losses, eddy losses, structural losses due to leakage fields) and load dependent - resistive losses (copper loss or  $I^2R$  loss) [3-4]. No load loss of the transformer can be minimized by using thin laminations, better grades of materials. Load-dependent losses can be minimized by using better conductor dimensions, changing the type of conductor, and optimizing the winding design [4]. Apart from above-

mentioned losses, the presence of magnetic material (like, core clamping structure, tank etc. made from mild steel) in the stray magnetic field causes additional losses in them that adds to the total loss of the transformer. Losses in structural parts resulted in thermal heating which leads to gasification of the transformer oil.

Total owning cost of the transformer includes loss capitalization. Minimization of the losses in any aspects is truly beneficial (in terms of owning cost) in today's competitive world. Therefore, a reduction in additional losses that occurs in mechanical structural parts which are relatively small compared to total losses of the transformer, become significant [1-2]. This paper proposed to use UDEL wood material as a core clamping structure instead of conventional mild steel clamping structure to reduce the stray losses. Being a non-magnetic material, the stray magnetic field could not link with UDEL wood and therefore no additional losses occur. With the proposed method one transformer is thoroughly analyzed with empirical formula and state-of-the-art software to verify its suitability under all extreme conditions. The results of the analysis are encouraging. Therefore, one 15 MVA, 66/11.55 kV class transformer is developed with UDEL wood clamping structure and successfully tested. From the test results, use of UDEL wood clamping structure can reduce the stray losses to take the

advantage in terms of the owning cost of the transformer. To verify the structural suitability of the UDEL wood to withstand short circuit forces, full scale dynamic short circuit test is conducted on the said transformer and it passed the test successfully. Presence of High voltage leads in the vicinity of the electric field causes partial discharges. Use of UDEL wood (itself is an insulating material) in high voltage zone can definitely reduce the partial discharges. To justify the low partial discharge performance of the transformer, Partial discharge test is also conducted and results are discussed.

## 2. TRANSFORMER OWNING COST

Transformer end cost/owning cost is a combination of Transformer cost (A - material purchase cost + transport + taxes and other costs) and loss capitalization cost (B - No-Load loss + C - Load Loss capitalization) i.e. [2, 5],

$$\text{Transformer owning Cost} = A + B \times \text{NLL} + C \times \text{LL} \quad (1)$$

From the above Eq(1), Loss capitalization cost has become a driving component to achieve low transformer owning cost. But, nowadays, Customer limits the values for Flux density and current density, thereby restricting designer to play with the material cost to reduce the overall cost of the transformer. Therefore, if by any means the total loss of transformer either no-load loss or load loss can be reduced, owning cost of the transformer can be optimized. The method described in the paper to reduce overall load loss by reducing stray loss can be encouraging to achieve cost optimized transformers.

## 3. CORE CLAMP STRUCTURE

In Transformer, the purpose of the core is to provide a low reluctance path to the magnetic flux. The core is built from laminations of CRGO (Cold Rolled Grain Oriented) materials [4]. These laminations of the core are clamped by a structure known as Core Clamping structure made from Mild Steel (MS) material. The main functions of the core clamps in any transformer are to clamp or exert pressure on the core laminations to hold it tight and do not allow any type of a movement in either normal operating condition or under any fault condition. Also, it ensures no air gap between the core laminations. Top core clamp exerts clamping pressure on coils through pressure rings. During the lifting of core-coil assembly, core clamp structure provides a cradle kind of structure to avoid undue stresses on laminations. Whereas, bottom core clamps provide support and base to core and winding assembly [6]. Figure 1 shows the typical arrangement of core clamping structure of the transformer. Tie Rods are provided for more rigid clamping structure and at the same time reduce the required thickness of the frame or core channel. Conventionally mild steel is used in clamping structure in view of easy availability & high strength.

## 4. STRAY LOSS

Stray losses are linked with the magnetic leakage field of the windings and leads. Stray losses occur in all metallic parts due to penetration of magnetic leakage flux. This magnetic leakage flux link with the metallic structure inside

the transformer and generates eddy currents resulting in additional losses and thermal heating of the structural parts. Transformer reactance increases with increasing radial gap between two windings allowing more dispersion of flux (leakage flux) resulting into higher stray losses. Total leakage flux increases approximately as the square root of the MVA rating for a particular value of percentage reactance [4].

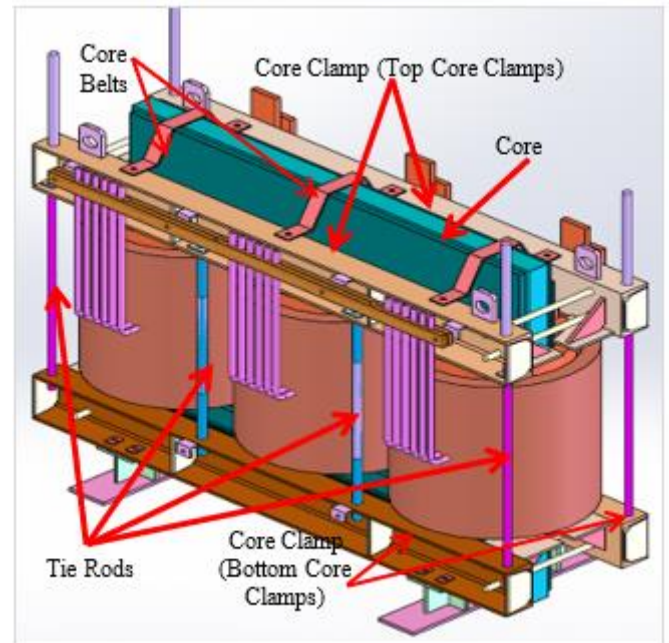

**Figure 1.** A typical arrangement of a clamping structure in the transformer

There are many locations inside the transformers where stray losses may occur [4], some of them are:

- 1.) Winding conductors due to eddy currents,
- 2.) Unloaded windings,
- 3.) Parallel strands of windings,
- 4.) Circulating currents in windings due to parallel conductors and transposition errors,
- 5.) Outer most core packets of the laminations due to penetration of very strong stray magnetic field of the windings.

Other than above mentioned locations, due to radial/axial magnetic leakage flux emanating from the winding links with core clamps and transformer tank walls. This linkage of flux with magnetic material (mild steel) induces eddy currents in structural parts resulting in additional losses due to their large surface area (which provides high resistance). Due to this additional losses, the possibility of generation of hot spots in structural parts which in turn results in the gasification of transformer oil during service conditions [6].

## 5. APPROXIMATION OF STRAY LOSSES

Calculation of stray loss is possible through empirical formula [7]. The stray loss in the ferromagnetic body is complicated due to the permeability of mild steel material and depends on the strength of the magnetic field. Elaborated experiments were done on transformers to investigate tank losses due to the linkage of flux and effects of shielding measures [7]. Relative permeability of the mild steel material

depends on Flux density (Tesla) and/or Magnetic Field Strength (Amperes/meter) [7]. An approximate empirical formula for calculating total stray losses occurring in tanks, core, flitch plates, tie rods, clamping structure, resulting from leakage flux is given below [7],

$$\text{Stray loss (kW)} = \text{Rated MVA} \times Z \times (5.67 - 1.77 \times \log_{10}(\text{Rated MVA}))/100 \quad (2)$$

where, Z = Short circuit Impedance of the transformer in percentage

## 6. LEAKAGE MAGNETIC FIELD INSIDE TRANSFORMER

The leakage flux links with metallic parts inside the transformer like core clamping structure, tank etc. causing additional eddy current losses in them. To investigate the leakage flux and their linkage with different metallic parts inside the transformer, FEM based analysis is performed using FEMM software. As shown in Figure 2, axial and radial magnetic leakage fluxes link with core clamping structure, tank and other structural parts resulting into stray losses. The stray losses due to this leakage field depend upon the amount of flux intensity in the vicinity of metallic materials, their permeability, and resistivity. In low resistive material, higher eddy current losses take place [6]. Leakage flux can be controlled by the appropriate placing of magnetic material or non-magnetic material in the path of the leakage flux.

### 6.1 Use of magnetic shunts & tank shields

As shown in Figure 2, axial and radial magnetic leakage fluxes link with core clamps and tank walls which generate eddy currents into them. This eddy current results into losses in metallic structure and may cause hotspot temperature rise of core clamps. Due to this, hotspot temperature rise, gasification of vicinity oil may take place. To avoid the linkage of leakage flux to the core clamping structure, magnetic shunts (made of thin lamination (0.23 mm to 0.35 mm thick) from CRGO – cold rolled grain oriented steel or CRNGO – cold rolled non-grain oriented steel) located between windings and core clamps are used to divert leakage flux back to core. Thin laminations of Magnetic shunts are suitably packed with pressboard material to avoid any partial discharges. Figure 2 (B) shows the location and effectiveness of yoke shunt to reduce the linkage of flux to the core clamps. But the presence of magnetic yoke shunts with sharp edges of CRGO laminations near to high voltage leads (termination of high voltage windings or leads going to bushing) can be a potential source of partial discharges. Therefore, additional clearance is required as shown in Figure 2 to facilitate the shunt in the window area of the core.

Figure 3 demonstrates the location and arrangement of the yoke shunt in the core-coil assembly structure. Yoke shunt laminations are packed with a suitable thickness of pressboard sheet to reduce the chances of partial discharge due to sharp edges of laminations and also reduce the required dielectric clearances from live parts. By experience, it is observed that yoke shunt provides almost 30% reductions in stray losses. Similarly, as shown in Figure 2, the magnetic leakage flux also links with tank walls and

creates additional stray losses in tank wall structure. To avoid linkage of leakage field to tank walls, CRGO or CRNGO material tank shields are used which covers the maximum area of the tank wall to provide a low reluctance path to leakage flux. Figure 4 shows the arrangement of tank Shield on the tank wall. Using tank shield almost 30% reduction in stray losses can be achieved. Considering yoke shunts and tank shields provided in a specific location inside the transformer, results in approximately 60% reduction in total stray losses [4].

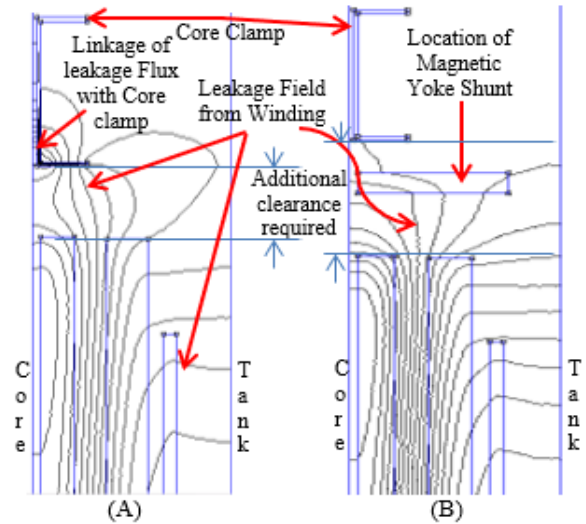

**Figure 2.** Linkage of axial/radial flux to the core clamp & Tank (A) without Yoke Shunt, (B) with Yoke Shunt

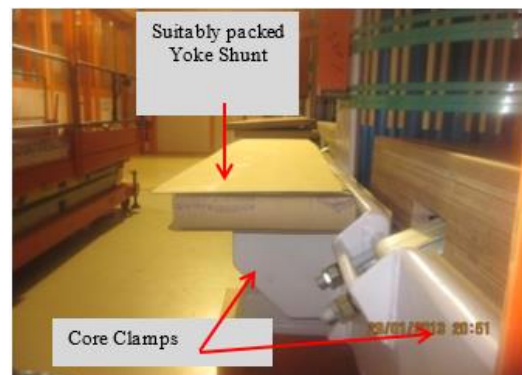

**Figure 3.** Location and arrangement of Yoke shunt

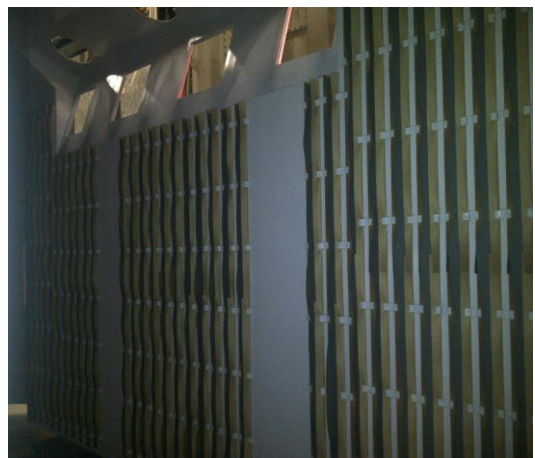

**Figure 4.** Location and arrangement of tank shields

## 6.2 Methodology to reduce stray loss

Stray losses in the transformer can be minimized by carefully handling the leakage magnetic flux using non-magnetic materials like stainless steel or wood. Stainless steel material is costlier than mild steel and Perma wood material. Perma wood material is used in the transformer as insulation from the beginning. It has shown comfortable behavior throughout the lifespan of the transformer. Perma wood material is used as a pressure ring to exert uniform pressure on the windings. UDEL (Unimpregnated densified electrical grade laminated) wood, being a non-magnetic and insulating material with better impregnation properties can be a good choice as an alternative to existing mild steel core clamp structure. However, the use of UDEL wood core clamps is limited to medium rating transformer up to 50 MVA due to dimensional constraints in manufacturing. UDEL wood is manufactured as per IEC 61061-2006 [8]. UDEL is defined as “Laminated wood made from layers of wood veneers bonded together under controlled conditions of heat and pressure using a thermosetting synthetic resin adhesive” [8]. For core clamps of UDEL wood, the P4R grade is generally used for better impact strength. Major material descriptions of a P4R grade is as per IEC 61061 [8]; where conventional mild steels are being manufactured as per Indian Standard IS 2062 [9].

## 7. DEVELOPMENT TRANSFORMER & ITS ANALYSIS

15 MVA, 66/11.55 kV Transformer is selected as development transformer. As per the specification of the end customer (utility), stray loss value should be less than 15% of total load loss. For calculation of owning cost of the transformer, capitalization specified on the load loss is of 2200 US\$ per kW, and penalty amount specified on measured loss is at every 1 kW of higher measured losses than specified, 3 times the loss capitalization amount need to be paid by the manufacturer of the transformer. To achieve this stringent requirement, only increase in copper weight to achieve desired load losses is not feasible. Therefore, UDEL wood core clamp is used to eliminate stray losses occur in mild steel core clamp. Also, to reduce stray losses in tank walls, tank shields are placed as discussed in section 6.1. Figure 5 and Figure 6 show the structural difference between core clamping structure using MS core clamp and UDEL wood core clamp respectively. To avoid linkage of leakage flux with MS core clamp, Yoke shunt is required while for UDEL wood core clamp arrangement, yoke shunt is not required.

### 7.1 Electromagnetic design verification

15 MVA Transformer is analyzed for box shape MS core clamp and UDEL wood core clamp for their dynamic short circuit integrity and electromagnetic performance using FEM based software. Figure 7 shows the outcome of the FEMM software with MS Box channel and yoke shunt. The result shows that most of the magnetic leakage field is absorbed by yoke shunt, thus allowing very less linkage of flux with core clamps which can still generate a small amount of stray losses in core clamps. Figure 8 explains the distribution of flux density in the region marked with the red line in Figure 7.

As seen from the Figure 8, at end of the winding phenomenon called fringing of the flux happened and due to that flux path redistributed according to reluctance offered by different magnetic materials. Therefore, around 90 mm distance (marked with a red circle where linkage of flux with yoke shunt is least) flux linkage is drastically reduced and again it builds up. To provide a shunt in high voltage region requires an additional clearance as discussed in section 6.1 which can further increase the cost of the transformer. In addition to this, the presence of thin laminations of core near to high voltage winding end leads to possible partial discharges in this region which may lead to failure at times.

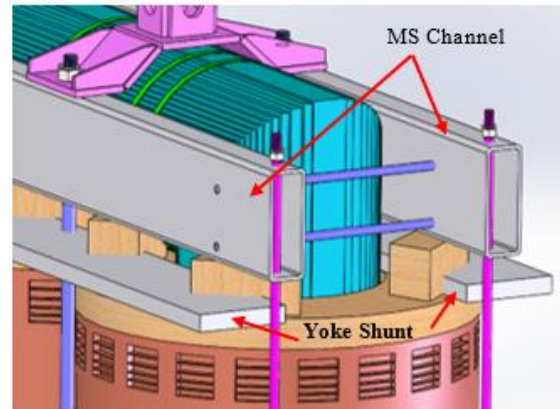

Figure 5. Core clamping structure using MS core clamps

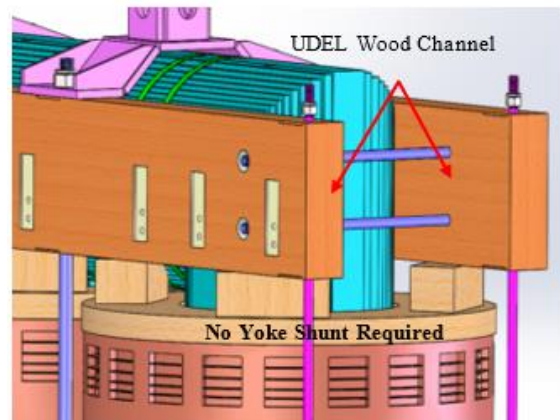
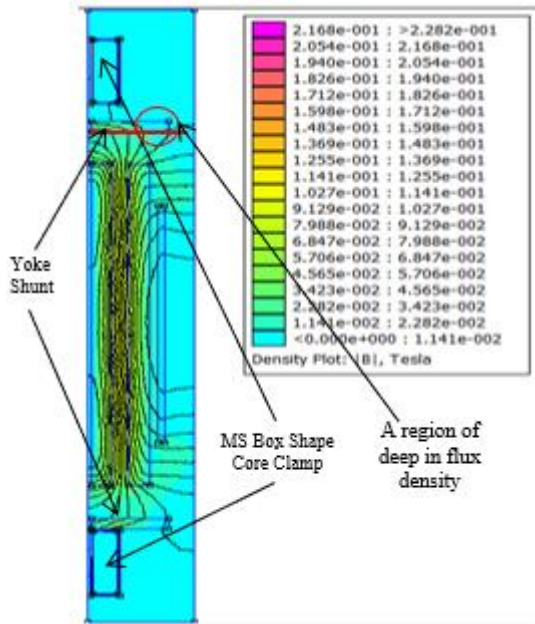
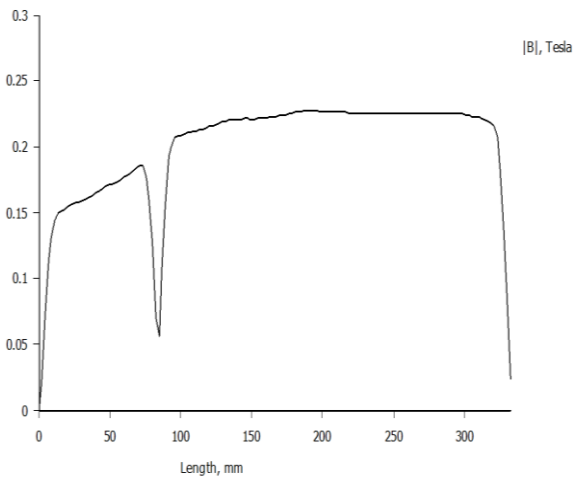

Figure 6. Core clamping structure using UDEL wood core clamps

Similarly, FEM based electromagnetic analysis is performed using UDEL wood core clamps and without yoke shunt. Figure 9 shows FEM based results when UDEL wood clamps are used without yoke shunt. UDEL wood beam being a non-magnetic cannot attract the leakage flux. Therefore, flux cannot penetrate to them and no chance of eddy currents to generate and therefore stray losses in core clamping structure can be eliminated using UDEL wood core clamps. Also, no additional clearance is required between windings and core clamps as no yoke shunt is used. This can further reduce the clearance requirement in window core area which gives an additional advantage in the cost of the transformer. Figure 10 shows the distribution of flux density near the vicinity of the UDEL wood core clamping region which is very less compared to one with the MS box core clamping structure as explained in Figure 8.



**Figure 7.** Flux density plot with MS Box core clamp



**Figure 8.** Distribution of Flux density at MS core clamp widthwise

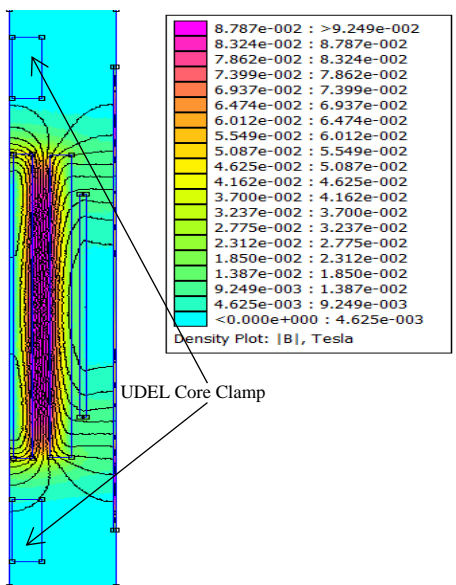

**Figure 9.** Flux density plot for UDEL wood core clamp

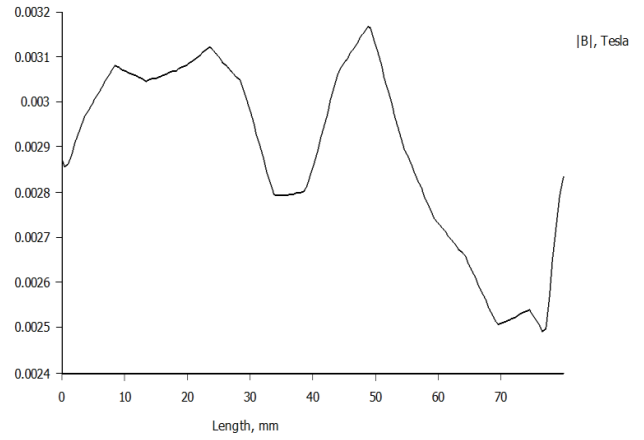

**Figure 10.** Distribution of flux density in the vicinity to UDEL wood core clamp UDEL wood core clamp – no linkage of flux to wood clamp & no stray loss

## 7.2 Electrodynamics design verification

Structural analysis of the MS Box core clamp and UDEL wood core clamp is performed using FEM based software to demonstrate their suitability under normal operating conditions and under dynamic short circuit fault conditions. For FEM study, only core clamping structure is generated and actual short circuit forces calculated using formulae given in [10] is applied. Deformation/Deflection of core clamps and maximum von-mises stress concentration are the main area of interest to study and compare the suitability of the proposed method. The obtained results are tabulated in Table 1. From the Table, the performance of the UDEL wood core clamp is comparable in terms of deformation and safety factor compared to conventional mild steel core clamp structure.

## 8. DISCUSSION ON ROUTINE TEST RESULTS

After thorough design verification by FEM software-based approach, development transformer is manufactured using UDEL with utmost care and under special treatments (storage, impregnation, and process) with the state-of-the-art facility. After satisfactory manufacturing, development transformer is subjected to routine tests (i.e. no load and load loss measurements, winding resistance, voltage ratio measurements, insulation resistance, dissipation factor test) as per IS 2026 – Part 1, cl. No. 3.6 [11].

Load loss is measured and results are compared with conventional mild steel core clamp structure transformer. Obtained tests results are tabulated in Table 2. An advantage of 28% in the stray loss with 4.6% in total load loss is achieved using UDEL wood core clamp as compared to the same design with conventional mild steel core clamp. This total load loss reduction gives a great advantage in total owning cost of the transformer.

After loss analysis, another characteristic need to check is partial discharge performance. Partial discharges are measured in pico coulomb (pC) in accordance with IS 2026 – Part 3: 2009, Cl. No. 12.2 [12]. The results are tabulated in Table 3 which shows that average 27% reduction is obtained in measured values of partial discharges (in pC) using UDEL wood core clamp structure compared to the MS core clamp structure. The observed low partial discharge performance is

not only due to use of UDEL wood core clamp structure but also due to the absence of yoke shunt in the high voltage region.

**Table 1.** Performance of Mild Steel core clamp and UDEL wood core clamp using FEM-based calculation under dynamic short circuit test condition

Core clamp material (Grade)	Mild Steel (E 350)	UDEL wood (P4R)
Parameters	Using FEM based Software	
Cross Section of core clamping structure (mm)	250 x 90 with 8 mm plate thickness	300 x 100 mm
Considered Load on core clamp structure under short circuit condition	10 Tons at 4 points	10 Tons at 4 points
Calculated Deformation (mm)	0.45	0.38
Maximum Von-misses stress (kg/cm <sup>2</sup> )	18.95	4.23
Allowed Stress (kg/cm <sup>2</sup> )	35	17
Safety Margin (Max. Stress/Allowed Stress)	1.85	4.02

**Table 2.** Load Loss of Transformer using conventional mild steel core clamp and UDEL wood core clamp

	MS core clamp with yoke shunt and tank shields	UDEL wood core clamp with same tank shield provision	% Reduction in losses obtained using UDEL wood core clamps
Load Loss at 75°C @ Tap 1 (W)	61627	58965	4.6
Load Loss at 75°C @ Tap 5 (W)	55404	52855	4.6
Load Loss at 75°C @ Tap 17 (W)	43282	41442	4.6
percentage stray Loss at 75°C *	11.67 %	8.38 %	28.2

Note: \* Percentage stray losses [7] are calculated by,

$$\text{Percentage stray loss} = \frac{\text{Measured Loss} - \text{Measured } I^2R \text{ loss} - \text{Design Eddy loss}}{\text{Total measured loss}} \times 100 \quad (3)$$

A developed transformer is successfully tested for all routine tests as mentioned at factory end. After that developed transformer is subjected to dynamic short circuit withstand test at NABL accredited testing laboratory in accordance with IS 2026: Part 5 [10]. Applied short circuit current is also calculated as per the standard [10]. Prior to short circuit test, Transformer is ready with all protection devices e.g., gas-and-oil actuated relays, pressure release device. Reactance measurement is performed on the per-phase basis and recorded to compare with post short circuit test reactance data. During each test applied voltages and currents oscillography recording are also taken to check any abnormality during the test. According to the standard, if measured reactance after short circuit test is within a maximum deviation of the order of 2% from the before test

measured reactance, transformer declared as passed the short circuit test [10]. Also, along with reactance, the physical external appearance of the transformer is also verified to check the possibility of any anomalies and/or operation of any protection system during or after the test as this may indicate an incipient fault inside the transformer. Also, the out-of-tank inspection of the transformer active part is carried out to reveal any defects such as displacement, the shift of laminations, and deformation of windings, connections or supporting structures. No significant changes should appear which might endanger the safe operation of the transformer [10]. Also, no traces of internal arc electric discharges are found. Figure 11 (A) and (B) shows the photographs of the transformer active part taken after a full scale dynamic short circuit test and no abnormalities are found during internal as well as external inspections. Also post short circuit measured reactance is well within 2% of the measured reactance before short circuit test. Therefore, the transformer is declared as successfully pass the dynamic short circuit test.

**Table 3.** Induced overvoltage withstand test with partial discharge (PD) measurement (IVPD test) of the transformer using conventional mild steel core clamp and UDEL wood core clamp

Applied Voltage Level (kV)	Partial Discharge values in pico Coulomb (pC) with ambient is around 7 pC								
	MS core clamp with yoke shunt and tank shields			UDEL wood core clamp & without yoke shunt with same tank shield provision			% Decrease in PD values using wood core clamps		
	Phases								
	U	V	W	U	V	W	U	V	W
46	35	38	38	26	24	24	26	37	37
94	128	132	135	97	96	96	24	27	29
132	Withstood								
94	121	128	136	98	92	94	19	28	31
46	33	37	36	27	27	26	18	27	28

## 9. CONCLUSIONS

Perma wood material pressure ring is an integral part of the transformer assembly for many years. The same material with better characteristics is used here for core clamping structure. Therefore, UDEL wood material is suitable for transformer core clamp structure. The mechanical strength of the core clamp is proved to withstand deformation and forces occurred during Dynamic Short circuit test with FEM software-based analysis and approved by withstanding Dynamic short circuit test. Stray loss reduction is the main aim of UDEL wood core clamp structure to be used over conventional mild steel core clamp and yoke shunt combination. The obtained results justify the use of the UDEL by getting a great advantage (reduction of 28.2% achieved) on a stray loss. By restricting the additional stray losses, the main advantage is saving of huge amount of energy loss (loss benefit of 4.5% achieved) in transmission lines. By reducing stray losses using UDEL wood, low load loss can give an advantage in the reduction in overall capitalization cost of the transformer which also justifies the cost of UDEL wood. UDEL wood being an insulating material and non-requirement of yoke shunt in the presence

of high voltage region of the transformer, the chances of the generation of partial discharges compared to conventional mild steel core clamp structure with yoke shunt arrangement is reduced to great extent. The obtained result of partial discharge level validates the statement of low partial discharge (reduction of average 27% is obtained) transformers. Hence, Proposed UDEL wood clamping structure method is found suitable in every aspect and sounds encouraging to reduce the total losses of the transmission system by reducing stray losses of the transformers. Also, the proposed method proves cost-effectiveness in comparison to conventional mild steel structure design. At the same time, it offers low partial discharges compared to conventional mild steel and yoke shunt arrangement.

## ACKNOWLEDGMENT

Authors are thankful for the management of M/s. Transformers & Rectifiers India Limited to facilitate and allow redesign, modify and test the transformer.

## REFERENCES

- [1] Wijayapala WDAS, Gamage SRK, Bandara HMSLG. (2016). Determination of capitalization values for no load loss and load loss in distribution transformers. *Engineer Journal XLIX(3): 11-20.* 10.4038/engineer.v49i3.7072
- [2] Douglas Getson PE. (2013). Energy efficiency cost of losses. ABB.
- [3] Kundu M, Jadhav S, Bagadia K. (2017). Technical loss reduction through active repair of distribution transformers: results from the field. 7th International Conference on Power Systems (ICPS), pp. 265–268.
- [4] Kulkarni SV, Khaparde SA. (2013). *Transformer Engineering- Design, Technology, and Diagnostics*, 2nd Edition, CRC Press USA.
- [5] Survilo J. (2017). Transformer design according to criteria and load profile. 58th International Scientific Conference on Power and Electrical Engineering of Riga Technical University (RTUCON).
- [6] Agarwal Y, Wadhawani MK, Raghavaiah BV, Hageria SCB. (2012). Stray losses in transformers – A CPRI experience. *International Conference on Emerging trends and challenges in Transformer technology*, CPRI, pp. 133-139.
- [7] Chiplonkar AV. (2008). *Design, operation & maintenance of core type oil filled power transformers*. Chapter 2, 1st Edition.
- [8] Non-impregnated densified laminated wood for electrical purposes, IEC 61061: 2006-10, 3rd Edition.
- [9] Hot Rolled Low, Medium, and High tensile Structural Steel IS 2062:2006, 6th Revision.
- [10] *Power Transformers, IS 2026:2011 – Part 5 – Ability to withstand short circuit*, 1st revision.
- [11] *Power Transformers, IS 2026:2011 – Part 1 – General*, 2nd revision.
- [12] *Power Transformers, IS 2026:2009 – Part 3 - Insulation levels, Dielectric tests, and External clearances in air*, 3rd revision.



(A)



(B)

**Figure 11.** Photographs of the transformer active part after full scale dynamic short circuit test