

A SMART GRID CLIENT-SIDE TESTING PLATFORM FOR MONITORING

QIU Wei-mei, GUO De-wei, ZHANG Chun-yan, XU Yun-xia and WANG Gan

School of Mechanical Engineering Shanghai University of Engineering Science, Shanghai, China.

Email: 38401293@qq.com

ABSTRACT

Power measurement circuit is calculated by the current and voltage data from the chip microcomputer, the power data sent to the main control circuit of motor. Main control circuit connected to the keyboard and display circuit, current, voltage, power of the motor and other data displayed in real time on a monitor, and the motor current and voltage according to the set of data to control the motor. This system also contains the RS485 interface, Ethernet-interface and CAN bus interface, supporting MODBUS, TCP/IP communication protocols, etc. It uploads the collected data and some data after processing to the sever terminal through the bus connection. The further data processing and monitoring can be controlled by the host computer. Realization for prevention of power before the accident and after rapid treatment. It is important for construction of the smart grid to form a unified system and intelligent client-side interaction, coordination. Thank you for your patience and cooperation.

Keywords: Smart grid, Motor protection, Software anti-jamming, Cycle monitoring.

1. OVERVIEW

With increasingly complex operating environment and electric power system reform continues to move forward, traditional power networks needs to be further improved. The terminal equipment in smart grid is not only getting more demanding, but also putting forward higher requirements in the intelligence and reliability. It is the direction of development of smart grid industry to use reliable, technologically advanced, highly automated, occupies small, less maintenance of equipment and installations actively, which is the inevitable result of the development of modern science and technology.

Smart grid is the rapid growth of technology, processes, devices, and applications. The new type of grid is formed by the modern advanced power electronics technology, sensor technology, information technology, computer technology and control technology highly integrated with the physical power.

2. IT IS USED AS A MOTOR PROTECTION

As a smart grid terminal, the three-phase motor is one of the equipment that is widely used in the electrical and mechanical trades. Most electrical applications have a very tough environment. If motor works in high temperature, high humidity, and dusty operating conditions for a long time, it is easy to make the motor broken.

The reasons for this phenomenon are in many aspects. The key problem is that motor protection technology is still

unsatisfactory in some respects. Malfunction and refusing to move often affect the normal use, thus, most users do not have or will protect the device to get rid of severe phenomena.

3. RESEARCH AND DEVELOPMENT TRENDS

Future motor protection technologies will be along two main directions of development. While advancing a new theory of study through the fault modeling and simulation calculation, then introducing sequence components and harmonic components, impedance, phase and other kinds of sensitive electrical fault detection criteria. Wavelet analysis, neural network, support vector machine algorithm are introduced into the field of motor protection control. It can not only greatly improve the performance of protection control device, but also the theoretical research of motor fault and protection will greatly promote. On the other hand, we have to attack the application and development of new technologies, using various sensors (including infrared, vibration, electrical, thermal, mechanical, electromagnetic waves, light, sound, etc.) to monitor motor operation. Then according to the sensor output information by the microprocessor to judge and classify. According to the provisions of various fault parameters of general technical conditions for digital motor comprehensive protection device to design different protection functions, such as the thermal overload protection, blocking protection, phase failure protection, phase unbalance protection, underload protection, leakage protection and start timeout protection, etc. Realizing

the function of power meter is to measure the power of three-phase motor. A good interactive feature not only can achieve a variety of motor protection function, and more importantly

can predict precursor to motor failure, then advance to prevent motor failure.

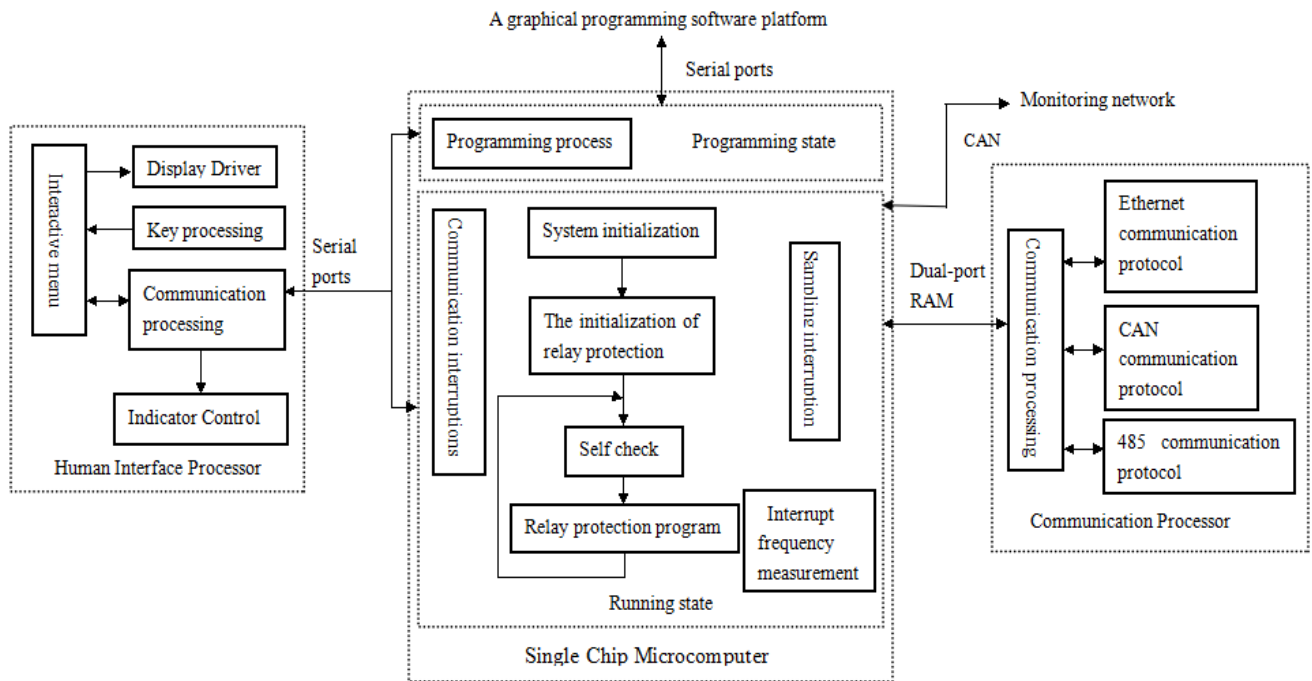

Figure 1. System composition block diagram

Protection of microcomputer type multifunctional protection is the microelectronics and computer technology applied to the protection, which is based on the SCM as the core, control, protection and communication functions and integrated intelligent comprehensive protection of electric motor. It has a high degree of flexibility, adaptability, stable performance and high reliability, judgment and strong features.

4. CIRCUIT DESIGN AND CALCULATION

The subject circuit comprising a chip at the core of the master. STM32F103RC is the control core of the whole

control system. It is based on ARM of ST company 32-bit Cortex™-M3 architecture for embedded micro-controllers. Its maximum operating frequency is up to 72MHz with single-cycle multiply and hardware divide function. Chip has 256K bytes of FLASH and 64K of SRAM and features 3-channel 16-channel 12-bit ADC and 2-channel 12-bit DAC with a 11-16-bit timer. Two advanced timers can be set with dead-time control and the emergency stop input of three-phase PWM generator. Also includes IIC, USART, CAN, a variety of USB2.0 communication interface and JTAG programming and debugging online interface peripherals, provides a good solution for the real-time control algorithm and system. Voltage and current transformer sample-and-hold circuit are shown in Figure 2 and Figure 3.

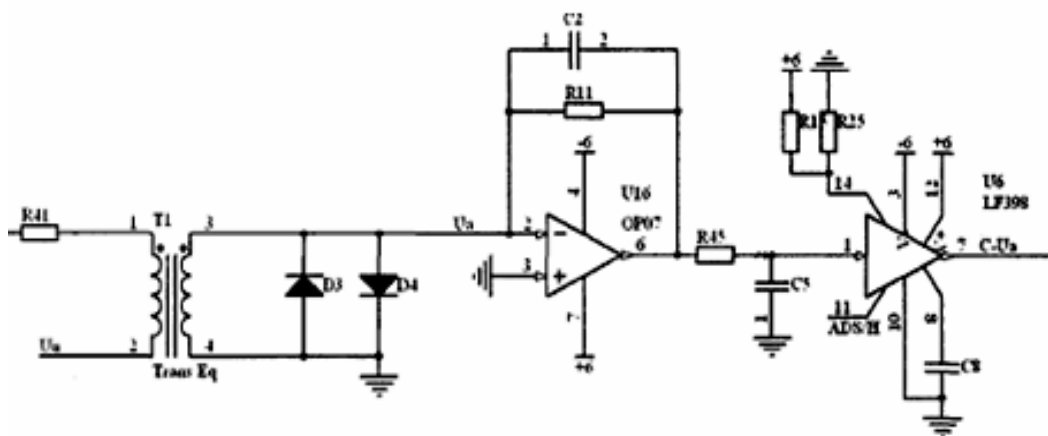

Figure 2. Voltage transformer sample-and-hold circuit

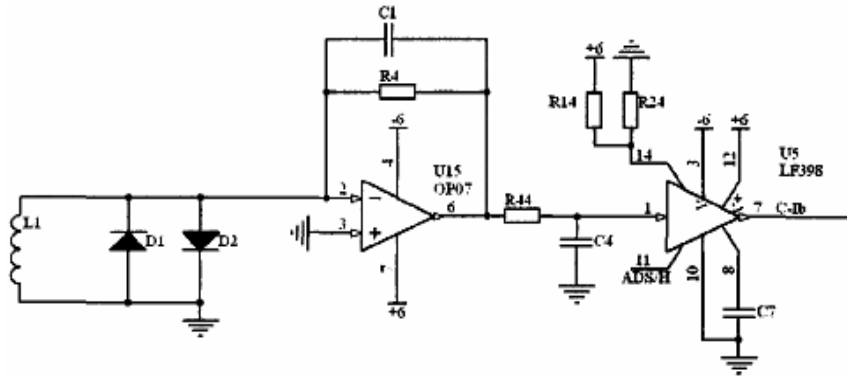

Figure 3. Current transformer sample-and-hold circuit

In addition there is a current processing circuit, voltage processing circuit, power measurement circuit, switching power supply circuit, keyboard, display circuit and communication circuit and other peripheral circuits, the overall structure, the current and voltage signal by the transformer after sampling via current processing circuit and voltage processing circuit is respectively connected to power measurement circuit and main control circuit. Power measurement circuit is calculated by the current and voltage data from the chip microcomputer, power data sent to the

main control circuit of motor. Main control circuit connected to the keyboard and display circuit, current, voltage, power of the motor and other data displayed in real time on a monitor, and the motor current and voltage according to the set of data to control the motor. The protection function can be achieved: thermal overload protection, blocking protection, open phase protection, underload protection, ground fault protection, undervoltage protection, starting overtime protection, etc.

When the above situation occurs, the main control circuit sends out control signal to cut off the power supply immediately, and display fault code on the display.

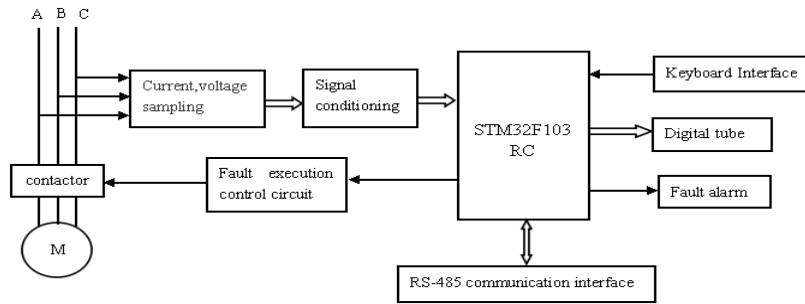

Figure 4. Block diagram of the circuit structure

The input voltage, current signal through the transformer, analog switch. Sample and hold circuit, analog-to-digital converter converts the AC signal into binary data, the application according to the conversion results to calculate the effective value of voltage, current value, active power, power factor, etc.

$$P_{\text{average}} = (U_1 \times I_1 + U_2 \times I_2 + U_3 \times I_3 + \dots + U_N \times I_N) / N$$

$$P_{\text{effective}} = [(U_1^2 + U_2^2 + U_3^2 + \dots + U_N^2) / N]^{1/2}$$

$$I_{\text{effective}} = [(I_1^2 + I_2^2 + I_3^2 + \dots + I_N^2) / N]^{1/2}$$

Where P is the power; U is voltage; I is a current; N is sampling points.

5. DYNAMIC MONITORING

With frequent electric accidents, some of them are man-made, but more are because of making mistake with the forecast of the Electric Peak or disrepair of the electricity

transmission lines, etc. According to the data from the testing and the judgement of the professionals, the building of the smart grid client-side testing platform can foresee the accidents and make fast reactions to deal with them when they happen. Meanwhile, the building of the platform will also make the statistics and modeling more convenient, which is easier to do the further research. Composing a united, interactional, concerted smart client terminal means a lot to achieve the building of the smart electric grid. Which means building the testing platform according to the situation of the smart grid client terminals' frequent accidents, making fast, accurate judgements to the power usage of all of the client terminals in one region, and achieving the fast reaction and the prevention after and before the accidents of the power using. As is shown in Figure 5.

This system, achieving the smart, multiple protection of the motor by testing the pressure and the current of the three-phase power supply, gathers protecting, testing, communicating and displaying as a whole. The current is setting digitally. Users can correct the parameter in field, according to the actual situation of the motor by using the buttons on the operation-board. This system also contains the RS485 interface, Ethernet-interface and CAN bus interface, supporting MODBUS, TCP/IP communication protocols, etc. It uploads the collected data and some data after processing to

the sever terminal through the bus connection. The further data processing and monitoring can be controlled by the host computer, such as: circulating monitoring, shutting down or

turning on on time, software alarms, data analysis, modifying parameters, etc.

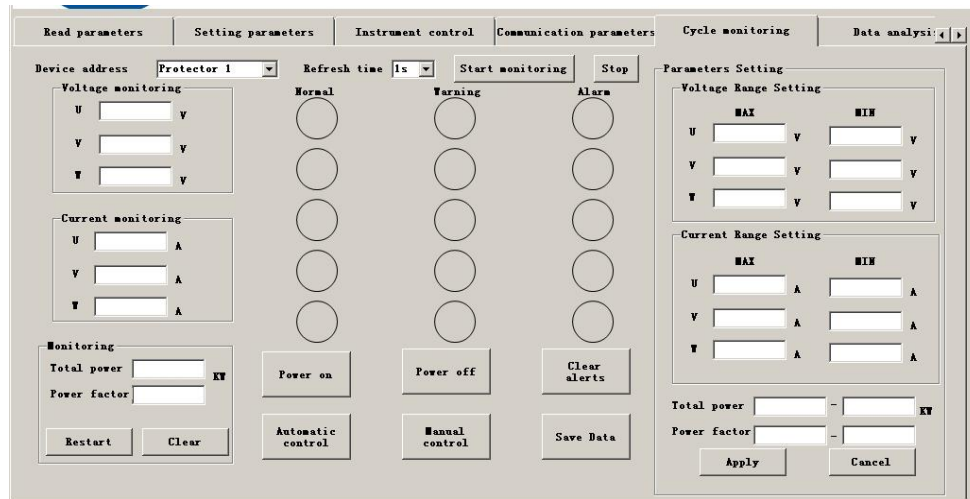

Figure 5. Monitoring windows

6. SOFTWARE ANTI-JAMMING

Software anti-jamming is benefited from the computer’s calculation capabilities, using appropriate mathematical methods and theories, digital filtering, devices and programs monitoring. It uses software trap, digital filters and other methods to ensure normal operation of the system.

(a) ADDING EMPTY COMMANDS

Adding NOPs between the two programs. When the MCU is disturbed, the pointer is not to the first command, but to the other command. After the pointer past the NOPs, the MCU will be back on the right track.

(b) USING SOFTWARE TRAP

Setting the software trap in the programming to capture the “runaway” instruction pointer, is a good means of monitoring whether the program runs a design exception.

(c) USING THE WATCH DOG TIMER (WDT)

The WDT is used to prevent the software being stuck in an endless loop. If the crash occurs, that program runs, the system cannot feed dogs normally. The timer will lead the program to reset.

7. CONCLUSION

The new smart grid client test platform is the highly intelligent electrical equipment and system that has many functions, such as bi-directional communication, load monitoring, fault prediction and early warning, the entire current range of selective protection, power quality monitoring, the realization of regional lock and fast security recovery. It consists of a client-side smart power distribution networks and even basic electrical equipment and system of the entire low-voltage power.

8. ACKNOWLEDGEMENTS

This work is supported by Shanghai University of Engineering Science High Level Project to Cultivate Special (Project No. cs1401012).

REFERENCES

- [1] CHENG Wushan, “Intelligent control of the complex technology process based on adaptive pattern clustering and feature map,” [J], *Journal of Mathematical Problems in Engineering*, 2008(6):256-263. .
- [2] Meng Yongpeng, Jia Shenli, Rong Mingzhe, “Application of frequency band energy decomposition using wavelet packet in condition monitoring of circuit breakers,” Xi’an Jiao-tong University, 2004, 38(10):1013-1017.
- [3] Nathan D. Jacob, William M. McDermid, Behzad Kordi, “Online partial discharge measurement of a high-voltage direct current converter wall-bushing,” [J], *High Voltage Engineering*, 2011, 37(11):2636-2641.
- [4] Meng Y.P., Jia S.L., Rong M.Z., “Mechanical condition monitoring of vacuum circuit breakers using artificial neural network,” [J], *IEICE Trans. on Electronics*, VOL. E88-C, 2005(8):1652-1658.
- [5] FLURSCHEIM, C.H., “Switchgear, a review of progress,” *Proc. IEE.*, 2008, 10(3) A, p.239.
- [6] CHORLTON, A., “Conception of the British 400kV system in design criteria and equipment for transmission at 400kV and higher voltages,” *IEE Conf. Publ.*, 15, 2007, p.9.
- [7] Cruz S.M.A., Cardoso A.J.M., “Rotor cage fault diagnosis in three-phase induction motors by extended Park’s vector approach,” [J], *Electric Machines and Power Systems*, 2000, 28(3): 289-299.
- [8] Nejjari H., Bnbouid M.E.H., “Monitoring and diagnosis of induction motors electrical faults using a current Park’s vector pattern learning approach,” [J], *IEEE Transactions on Industry Applications*, 2000, 36(3): 730-735.