

## THE OPTIMIZATION DESIGN OF MICRO-CULTIVATOR BLADE USED ON SLOPING FIELDS

Lu Jianfeng\*, Zhang Keke and Zhang Fugui

\*College of Mechanical Engineering, Guizhou University, Guiyang, 550025.

Email: cmejflu@gzu.edu.cn

### ABSTRACT

This paper introduces the limitations of ordinary rotary cultivator blade. The structure design, static simulation analysis and optimization design of the rotary machete used on sloping fields were finished, and compared with and analyzed the simulation results of the ordinary rotary machete. At the same time, it made a checking calculation on the effective clearance angle of rotary machete used on sloping fields.

**Keywords:** Micro-cultivator, Blade, Analysis, Optimization.

### 1. INTRODUCTION

Due to the influence of the slope, using ordinary micro-cultivator blade to cultivate would make the slope soil move down gradually, and make the bottom part of the soil get thicker but the top thinner gradually. Then the growth of crops will be restrained by the thinner soil coverage. To protect the sloping fields, we need to design a specialized cultivated blade used on sloping fields, it should make the soil keep a relatively unchangeable position in the whole cultivation process, finally to achieve the stability of sloping fields.

### 2. DESIGN OF ROTARY BLADE USED ON SLOPING FIELDS

#### 2.1 Selection of blade and the design of cutting edge

At present, there are multiple types of rotary blades, such as L-shaped, straight, machete, etc. According to the cultivated situation of sloping fields, machete was chosen as the main part of micro-cultivate used on sloping fields. The concrete structure is shown in Figure1. When the machete working, firstly the side cutting edge close to the axis cuts the soil along the portrait, from the close to the distance, finally the tangent cutting edge cuts along the landscape. In this process, residues and grass stems are pinned to the fallow soil, cutting with support point, which makes them easier to be cut off, even if not, residues and grass stems can also leave the machete along the cutting edge, and wouldn't wind together.

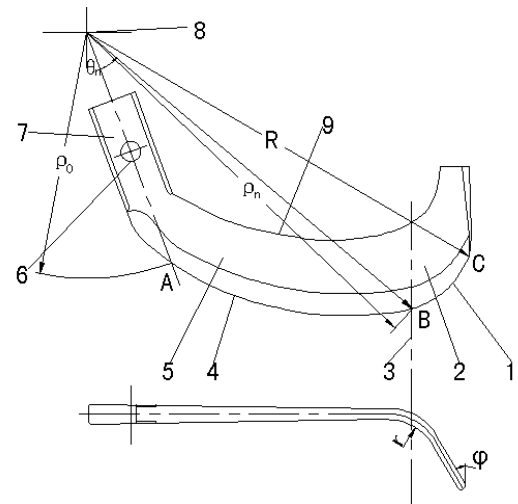

**Figure 1.** The structure of rotary machete

1. Tangent cutting edge
2. Front-end part
3. bending lines
4. side cutting edge
5. Side cutting part
6. Installing hole
7. hilt
8. knife roll center
9. Trailing edge

The design of rotary machete includes two parts: the side cutting edge  $\frown AB$  and the tangent cutting edge  $\frown BC$ . At present, side cutting edge is commonly Archimedes spiral of present production of kinds of machete in China, and its equation is:

$$\rho = \rho_0 + \alpha' \theta \quad (1)$$

Where,

- $r_0$  – modulus of spiral starting point, mm;
- $a'$  – augments of modulus when spiral polar angle increase 1 rad, mm;
- $q$  – polar angle of any point on spiral, rad.

Modulus of spiral ending point, its equation is:

$$\rho_n = \rho_0 + \alpha' \theta_n \quad (2)$$

To avoid the none-blade part of the tool cutting soil, the modulus of spiral starting point should be:

$$\rho_0 = \sqrt{R^2 + S^2 - \sqrt{2Ra - a^2}} \quad (3)$$

Where,

- $R$  – gyration radius of rotary machete;
- $S$  – pitch of cultivate ;
- $a$  – depth of cultivate.

The shape of tangent edge of rotary machete is a space curve. When the projection of the curve is an arc on the left view, namely, the curve is on the outer cylindrical surface of knife rolls, the cultivate bottom is relatively flat and tidy. The side cutting edge and the tangent transfer smoothly via an arc. In a three-dimensional Cartesian coordinate system, the curve equation for the tangent cutting edge is:

$$x = \rho_0 \sin(\theta_{\max} + \varphi_n) \quad (4)$$

$$y = \rho_0 \cos(\theta_{\max} + \varphi_n) \quad (5)$$

$$z = \rho_0 [\sin(\theta_{\max} + \varphi_n) - \sin \theta_{\max}] \cot\left(\frac{\pi}{2} - \beta\right) \quad (6)$$

$$0 \leq \varphi_n \leq \varphi_{\max} \quad (7)$$

Where,

- $r_0$  – modulus of side cutting edge starting point;
- $q_{\max}$  – maximum polar angle of the maximum side cutting edge;
- $j_n$  – coordinate polar angle of any point on tangent cutting edge;
- $b$  – bending angle.

## 2.2 Structure design and optimization of rotary machete used on sloping fields

### 2.2.1 Structure design of rotary machete used on sloping fields

The design of rotary machete used on sloping fields is based on the ordinary one. In order to make soil turn to inside of the fuselage when the micro-cultivate are working, the rotary cultivate blade is bended to inside, then the soil would not move down the slope. The difference between the two structures are shown in Figure 2 and Figure 3:



Figure 2. Bottom view of ordinary rotary machete

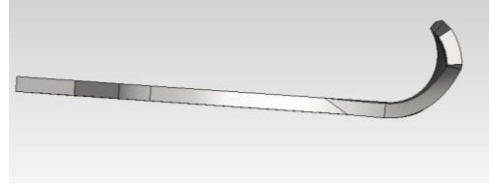

Figure 3. Bottom view of rotary machete used on sloping fields

### 2.2.2 3D modeling of rotary machete used on sloping fields

The twist angle is chosen initially, namely, the blade inward bending angle is  $5^\circ$ . The 3D modeling of the rotary machete used on sloping fields was modeled by SolidWorks, and it is shown in Figure4 and Figure5:

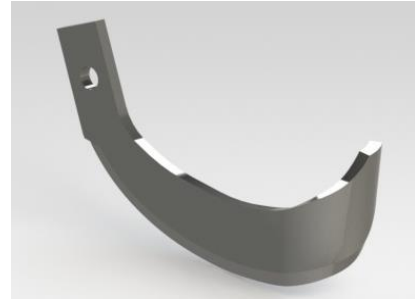

Figure 4. Left tilling blade

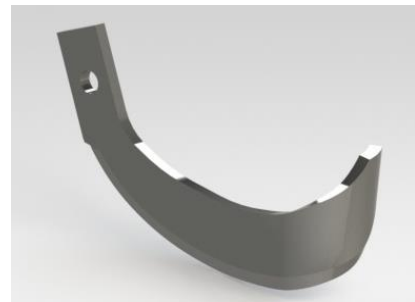

Figure 5. Right tilling blade

### 2.2.3 Optimal design of rotary machete used on sloping fields

In order to make the inward bending Angle more reasonable, the twist angle of rotary machete used on sloping fields need to optimize.

The primary stress analysis and optimization design of the rotary machete used on sloping fields was finished in SolidWorks Simulation. Firstly, the model of the machete was meshed, then according to its actual working situation, a fixed constraint is imposed in the installing hole on its handle to fixed its movement and rotation in the X, Y and Z direction,

finally an external concentrated load:  $F=500N$  is imposed on the blade.

The material is steel 65Mn, its yield strength is 430Mpa. Considering the complex shape of the tool may affect the strength, and steel 65Mn belong to plastic material, thus  $n=1.5$  is selected as the safety factor,  $[\sigma] = 2.867 \times 10^8 N/m^2$  as the allowable stress.

According to the above analysis, setting such optimum conditions to make a structure optimization analysis of the machete. The twist angle is set as variability. In addition, the minimum value and the maximum value are  $1^\circ$  and  $15^\circ$ , and its step value is  $1^\circ$ . Meanwhile, setting pressure as constraint conditions and the stress ranges from 0 to  $2.867 \times 10^8 N/m^2$ . It is the ultimate objective function to achieve a minimal quality.

### 2.2.4 Optimal design of rotary machete used on sloping fields

In the optimization analysis of SolidWorks Simulation, there are 15 times analysis on the objective function within the setting variable range, and get the relation curves among design variables, constraint conditions and objective functions, it is shown in Figure 6:

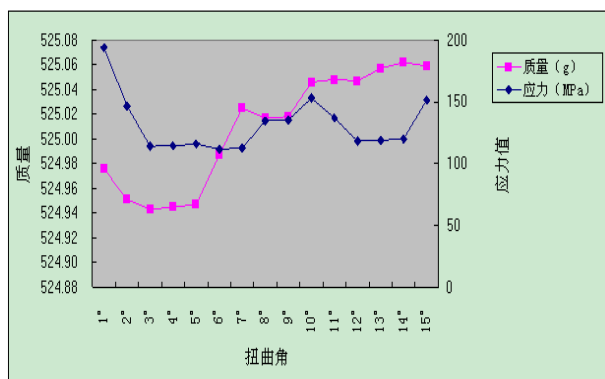

Figure 6. Relation curves graphic among design variables, constraint conditions and objective functions

From Figure6, it could be found that when the twist angle increased gradually, the quality of the machete edged decreased. As the angle reach  $3^\circ$ , the quality would reach a minimum value, then the quality curve keep rising. When the angle is less than  $7^\circ$ , stress of the machete decreased gradually with the increase of the angle. But the stress would decreased in a small range, when the angle is between  $7^\circ$  and  $10^\circ$ .

From above analysis, the twist angle of the rotary machete used on sloping fields is  $3^\circ$ .

### 2.3 Checking calculations of the available clearance angle of the rotary machete used on sloping fields

If the clearance angle is less than or equal to  $0^\circ$ , it would lead some bad results in the process of cutting soil used the tangent blade of the machete, such as the external grinding surface would contact the unplugged land, the whole machine power consumption would increase, more seriously, the micro-cultivator couldn't work normally because of its intense vibration. According to agricultural machinery designing handbook, the working available clearance angle of the rotary machete should be set from  $1^\circ$  to  $3^\circ$ .

According to the structure of the machete, the nominal cutting angle of the designing machete is  $\nu = 35^\circ$ , and the grinding angle in the vertical section of the tangent blade is  $i_v \geq 21^\circ$ , and the width of the external grinding surface is  $h' \approx 12mm$ . Within available working conditions of the micro-cultivator, seriously, there are some parameters that the knife rolls' rotational speed is lower limit,  $n = 190r/min$ , and the machine's toward speed is upper limit,  $v_m = 5km/h$ , and 14cm as cultivate depth. After calculating, when the designing machete working in an available conditions, the available minimum clearance angle should be  $2.7^\circ$ , the external grinding angle wouldn't contact the unplugged land and the selected nominal cutting angle and the grinding angle is reasonable.

### 3. COMPARATIVE ANALYSIS BETWEEN ROTARY CULTIVATOR USED ON SLOPING FIELDS AND NORMAL ROTARY CULTIVATOR

The statics analyzing of the two types of rotary machete, and the imposed conditions keep the same as mentioned, the analyzing results is shown in Figure7~Figure10. When the twist angle is  $3^\circ$ , the stress of the rotary machete used on sloping fields is 151MPa, quality is 524.943g and the deflection is 0.556mm. However, under the same conditions, the stress of the normal one is 170MPa, quality is 5240941g, the deflection is 0.452mm. According to the above comparative data, it could be found that the stress of the rotary machete used on sloping fields is less than the normal one, but the quality and the deflection increased a little more.

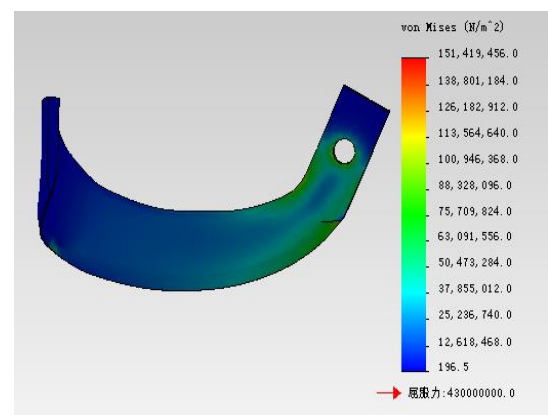

Figure 7. Stress diagram of the rotary machete used on sloping fields

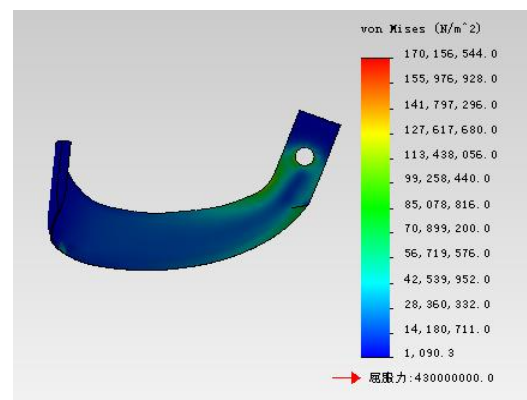
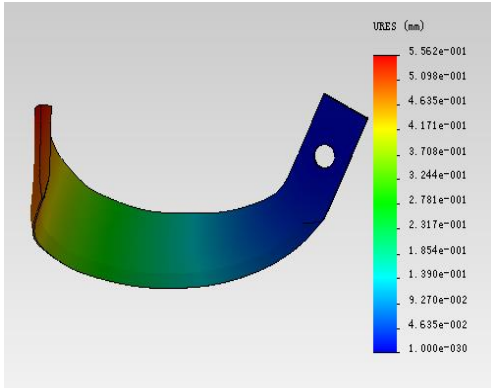
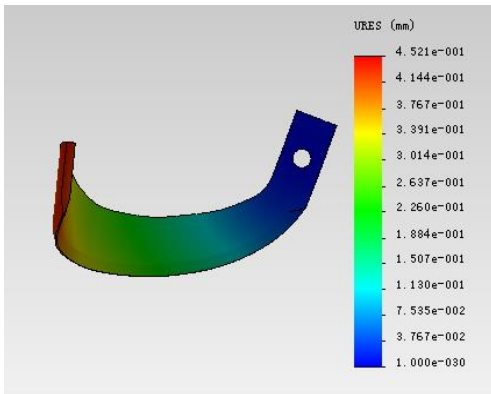

Figure 8. Stress diagram of the normal rotary machete



**Figure 9.** Displacement diagram of the rotary machete used on sloping fields



**Figure 10.** Displacement diagram of the normal rotary machete

#### 4. CONCLUSION

- (1) The designing rotary machete used on sloping fields can prevent the slope soil moving down in the process of cultivate.
- (2) The stress of the rotary machete used on sloping fields is less than the normal one, but the quality and the deflection increased a little more.
- (3) When the designing rotary machete working in an available conditions, its available minimum clearance angle

should be  $2.7^\circ$ , and the external grinding angle wouldn't contact the unplugged land.

#### ACKNOWLEDGMENT

The project is supported by Foundation of Guizhou University (No. [2009]036).

#### REFERENCES

1. Nianchao Jiang, Cuiying Chen, Surface Modeling of Rotary Cultivator Based on the NURBS Theory, *Transactions of the Chinese Society for Agricultural Machinery*, 2002.3.3(5), pp.126-128.
2. Ge Yun, *The Stress Simulation and Reliable Design for the Main Working Parts of Self-propelled Rotary Cultivator ShiHeZi*, ShiHeZi University, 2005.
3. Xiaodong Zhang, Zhimei Du, Research Design of 1GW-6.8 Micro-Cultivator Used Indoors, *Farm Machinery Using & Maintenance*, 2006(6), pp. 12-14.
4. Zhangxia, Zongshou Cai, Deguang Wu, Research on Designing the Whiling Blade Radius of Horticultural Cultivator, *Journal of Yunnan Agricultural University*, 2006.2.1(2), pp.250-255.
5. Zhangxia, Zongshou Cai, Deguang Wu, Study on Blades of Self-propelling Cultivator, *Journal of Yunnan Agricultural University*, 2006.2.1(1), pp.103-106.
6. Zongshou Cai, Zhangxia, Guizhong Lu, Optimization Design of Roller-Speed Ratio of Self-propelling Cultivator, *Journal of Yunnan Agricultural University*, 2006.2.1(5), pp.677-680.
7. Wang Ze, 1Gd-40 Type DC Electric Multi-functional Micro-cultivator, *The Equipment and Technology of Agriculture*, 2007.3.3(2), sp-56.
8. Gaofeng Yue, Xuying Yang, Diao Fei, Modular Design of the Micro-cultivator Based on SolidWorks, *Journal of Agricultural Mechanization Research*, 2009(2), pp.80-82.
9. Zhirong Zheng, Analysis and Structure Optimization of Small Rotary Cultivator's Broken Mechanism, NanNing, GuangXi University, 2010.