



The Energy Center Initiative at Politecnico di Torino: Practical experiences on energy efficiency measures in the municipality of Torino

Romano Borchiellini, Stefano P. Corgnati, Cristina Becchio, Chiara Delmastro, Marta C. Bottero, Federico Dell'Anna, Andrea Acquaviva, Lorenzo Bottaccioli, Edoardo Patti, Ettore Bompard, Enrico Pons, Abouzar Estebarsari, Vittorio Verda, Massimo Santarelli, Pierluigi Leone, Andrea Lanzini*

Energy Center Lab, Politecnico di Torino, C.so Duca degli Abruzzi 24, 10129, Torino, Italy

Email: andrea.lanzini@polito.it

ABSTRACT

Urban districts should evolve towards a more sustainable infrastructure and greener energy carriers. The utmost challenge is the smart integration and control, within the existing infrastructure, of new information and energy technologies (such as sensors, appliances, electric and thermal power and storage devices) that are able to provide multi-services based on multi-actors and multi and interchangeable energy carriers. In recent years, the Municipality of Torino represents an experimental scenario, in which practical experiences in the below-areas have taken place through a number of projects: 1. energy efficiency in building; 2. smart energy grids management and smart metering; 3. biowaste-to-energy: mixed urban/industrial waste management with enhanced energy recovery from biogas. This work provides an overview and update on the most interesting initiatives of smart energy management in the urban context of Torino, with an analysis and quantification of the advantages gained in terms of energy and environmental efficiency.

Keywords: Biowaste-to-Energy, Energy Efficiency, Urban Environment, Energy Planning Policies.

1. INTRODUCTION

Urban settlements are largely energy-intensive. According to the UN habitat division, cities consume about 75 per cent of the global primary energy supply and are responsible for about 50-60% of the world's total greenhouse gases [1]. Moreover, most of the energy is still supplied by fossil fuels (coal, oil and gas). Indeed, most of the population lives in dense urban areas. In 2016, more than half of the overall world's population lived in urban settlements. By 2030, urban areas are projected to house 60 per cent of people globally and one in every three people will live in cities with at least half a million inhabitants [2].

Creutzig et al. [3] found a positive correlation between energy use in cities and economic activity by analyzing 274 cities differently sized and worldwide distributed. Especially, the observed correlation between energy use and per capita gross domestic product (GDP) is marked below 10,000 USD/person. There is also a milder, still positive, correlation for values up to 30,000 USD/person. One of the key findings of the study was that economic activity, transport costs, geographic factors, and urban form explain 37% of urban direct energy use and 88% of urban transport energy use. Hence, there is a great opportunity for reducing the energy footprint of cities by promoting greener mobility options. Whether based on battery electric vehicles (BEV) or fuel cell

electric vehicles (FCEV), electron mobility requires the re-charging of the energy carrier (either electricity or hydrogen) to the vehicle being powered by renewable electricity. Interestingly, both BEV and FCEV mobility options could also provide co-benefits to the grid. BEVs can be exploited in 'power-to-vehicle' (P2V) and 'vehicle-to-grid' (V2G) configurations to store and provide power from and to the distribution grid [4].

Recently, the use of FCEVs as household power generators was proposed [5]. The parked vehicle will produce electric power to meet part of the residential load while consuming a share of the onboard stored hydrogen. The extension of the concept of 'car as a power plant' in the context of smart cities has been described in the work of Oldenbroek, Verhoef and van Wijk [6]. The authors concluded solar and wind electricity together with FCEV used also as energy generators could provide 100% renewable energy to smart cities (thus covering power, heat, and transport demands).

Focusing now on the energy supply and demand in the residential sector (i.e., households), about one-third of the energy is consumed for heating in northern Europe climates. The decarbonization of the heating sector is thus another key factor for reducing the energy use in cities [7].

The decarbonization of the heating sector can be reached by a combination of demand reduction and cleaner heat generation. Several options for retrofitting the existing

building stock are available [8] in order to reduce the energy use. Toward a cleaner heat generation mix, many solutions can be explored according to local resource availability.

In the near future, three energy grids are actually expected to compete against each other in the heating sector: heat networks, gas networks and electric grids. In areas characterized by high heat densities, district heat can represent an interesting solution for exploiting local excess heat, combined heat and power technologies and renewable energy sources. Nevertheless, building renovation will drive consistent thermal demand variations over time impacting over district heat planning strategies [7].

The injection of H₂ and biomethane into the existing gas grid could represent an option for decarbonizing the heating sector (fossil gas is gradually replaced by green gas in this scenario) [9]. The electrification of heating is also a viable scenario under which the surplus of renewable electricity for intermittent power sources (PV, wind) is available.

Finally, the exploitation of renewable energy sources in the urban land area is quite limited. Rooftop PV generation could be exploited on the urban scale to provide onsite renewable energy [10]. However, the potential of PV generation in the densely populated urban area is limited. Another source of green energy for cities could come from biowaste-derived biogas. The organic fraction of municipal solid waste (OFMSW) and sewage sludge represent two valuable sources of biowaste that can be exploited to produce biogas. Biogas is then available either for on-site combined heat and power (CHP) generation or for injection into the gas network after purification (an upgrade purification step is required to remove CO₂ and fuel contaminants such as H₂S and siloxanes [11]).

In this work, we will present an overview of energy efficiency measures currently ongoing in the municipality of Torino (Italy). Both practical experiences and simulated scenarios for the city have been carried in the last years to promote a transition toward a greener and more sustainable urban society. Energy efficiency measures in the urban environment are one of the activities carried out by the Energy Center at Politecnico di Torino. The Energy Center Initiative (ECI) was launched in 2017 to start a series of actions and projects that will provide support and advice to local, national and transnational authorities on energy policy and technology. The first case study will be the City of Torino. A densely populated urban area is indeed an ideal case to test how digitalization and energy can pair together for a more sustainable society. Buildings and mobility are indeed among the most energy-intensive sectors of an urban settlement. Finding ways for determining the optimal mix and allocation of local energy grids (gas, electricity, and heat) while maximizing local energy production from RES is the key goal of the research.

The municipality of Torino has already experienced many research activities and projects related to the previously mentioned subjects. This paper summarizes some of the most relevant projects in the field of urban energy efficiency. In Section 2, we report on activities in the building sector with a focus on the simulation of the energy and environmental impact of retrofit measures applied to urban districts rather than single building units. Section 3 describes activities connected to the smart management of energy grids and the role Information and Communication Technologies (ICTs) have in both planning and monitoring of distributed energy sources at the urban scale. Finally, section 4 presents some opportunities for combined heat and power generation from

urban bio-waste management.

2. ENERGY EFFICIENCY IN BUILDINGS TOWARD LOW-CARBON SOCIETY

The European Commission's Roadmap showed that greenhouse gas' (GHG) emissions in the building sector could be reduced by around 90% by 2050 compared to 1990. The most immediate and cost-effective way of achieving this target is through a combination of cutting energy demand in buildings through increased energy efficiency and a wider deployment of renewable technologies. Consequently, European legislation introduced the zero-energy target at the building level to achieve the reduction of greenhouse gas' emissions produced by the building sector. The challenge set by EU Commission with regard to nZEBs should necessary evoke a wide scenario, in terms both of time and of scale. Indeed, nZEBs will be regulated until 2020 but the common perspective consists of a vision towards 2050. The existing building's retrofit with its significant potential for both cost-effective CO₂ emissions mitigation and substantial energy consumption reduction can be seen as Europe's biggest energy resource playing a crucial role in hitting 2050 targets. At the same time, measures to increase energy efficiency in buildings support several other important societal and individual goals, such as increased employment and an enhance to economic activity, improved quality of life, reduction of fuel poverty and better security of supply with its lower dependence on imported fossil fuels. Moreover, the Commission is moving the matter with a steady increase from the single building level to the district and the city one. Especially in the existing building stock, it is not sufficiently effective working at the single building level but it is necessary defining accurate and specific strategies for planning the energy efficiency of the whole stock. This is testified by the fact that over the last few years there has been a wealth of academic and practitioner debates on realizing more socially and environmentally sustainable cities through a number of overlapping concepts such as low impact, carbon reduction, eco-urbanism, low-carbon, zero-carbon, and currently post-carbon. This last concept of "Post-Carbon City" (PCC) should have a decisive effect on the building design, in terms of envelope technologies and system components, and, especially, in terms of sociological aspects referring to the interaction between the occupant and the building itself, and the building and the other buildings in the district. Sørnes et al. [12] highlighted that the better performances of the zero-energy concept on a larger scale, rather than a single building, will improve the energy and greenhouse gas emissions' saving, and could trigger an economy of scale to achieve cost optimality with current market prices. According to [13], it is only combining a number of consumers that certain solutions or technologies (as district heating, cogeneration, biomass, and solar energy) can provide alternative strategies, which are not appropriate to a single consumer, either for technical or for economic reasons.

The evaluation of different alternative retrofit scenarios is fundamental in order to develop some local energy planning policies. In fact, energy planning can be supported by the definition of several future scenarios to investigate the impact of various different alternatives, providing a strategic decisional framework [14], [15]. Traditionally, local energy planning is performed by following a sectorial approach [16], leading to neglect the long-term effects of sectorial policies on

the whole energy system [17]. A cross-sectoral integrated approach, such as the one provided by energy system models [18], allows investigating the impacts of sectorial measures on the entire urban energy system, supporting an optimal mix of resource allocation in energy plans. Moreover, when speaking about energy planning and energy district projects, many objectives have to be considered in the decision making process: factors that range from the reduction of pollutant emissions to the investment cost, from the increase in indoor comfort to the creation of benefits in term of real estate assets value. Consequently, it is essential having methodologies and tools characterized by multi- and inter-disciplinary approach. Cost Benefit Analysis (CBA) and Multicriteria Decision Analysis (MCDA) represent useful tools into the energy efficiency decision-making framework.

This paragraph summarizes three relevant experiences related to energy planning applications in the Municipality of Torino (North Italy).

2.1 Defining heat decarbonization strategies through integrated urban energy planning

To avoid the limitation associated with a sectorial planning approach, the city of Torino investigated the applicability of an integrated energy planning procedure [19] at the local scale. In this context, this paragraph briefly describes the results of a methodology developed in the framework of cooperation between the Politecnico di Torino and the International Energy Agency. The research activity focused on exploring integrated heat supply and building envelope investment choices to 2050. The study, included in the ETP-2016 Chapter 4 [7], has been developed for providing policy and market insight for policy makers and energy providers. The methodology also allows estimating future heat loads under different building renovation packages to design compatible policies for the district heating system.

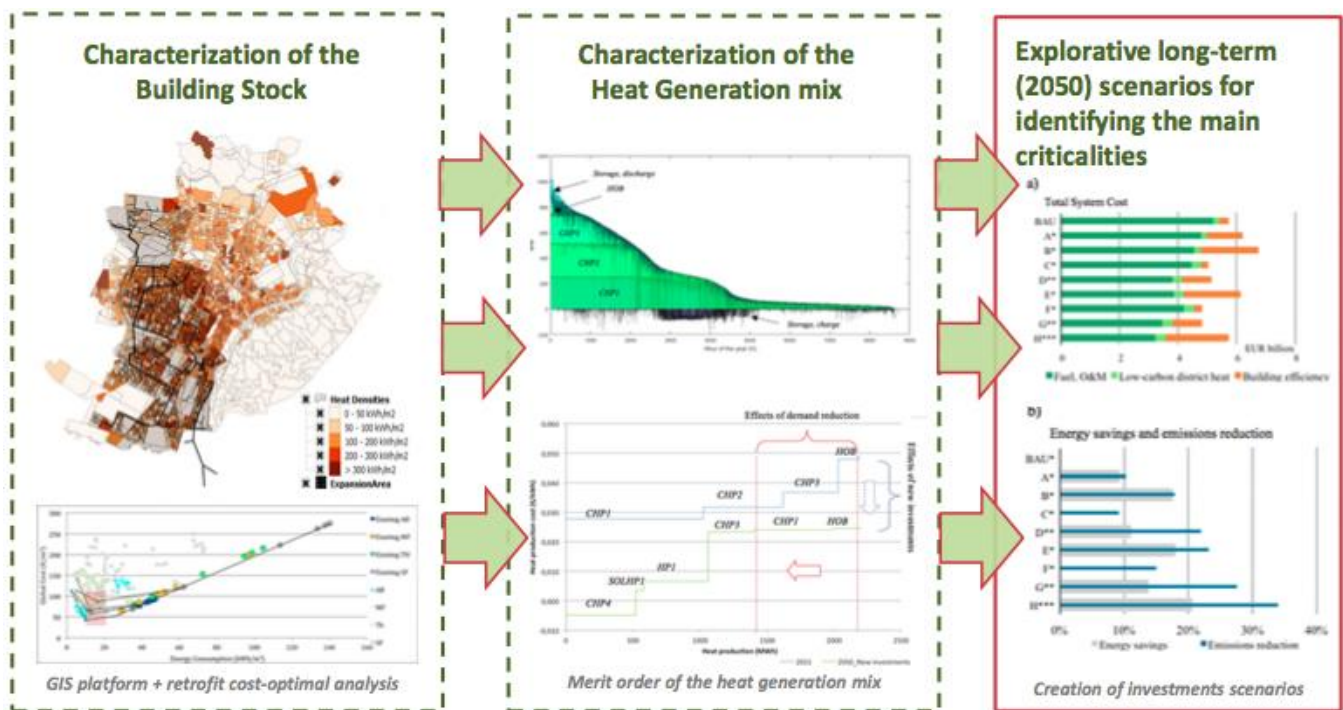

Figure 1. Steps for generating long-term scenarios for the heat demand in the building stock of Torino

As can be observed in Figure 1, a building model has been coupled with a heat generation mix model for studying long-term (up to 2050) evolutions of the energy system under an economic, energetic and environmental perspective. The integrated model simulates the operation of the district heat system to supply a given set of energy demands. The model operates in hourly time-steps over a one-year time-period, and combine such annual results into a scenario of 35 years. In the final model, the thermal demand variations, relative to building renovation options, are the input of a district heat simulation model. The district heat model is developed to evaluate the heat production costs when the system is subjected to several investment assumptions (generation technologies and network expansion). For each proposed scenario, the total life cycle cost of the energy system and emissions reduction has been estimated.

The analysis has been defined by 5 relevant steps: 1. Creation of a georeferenced database for the characterization of building thermal demands; 2. Identification of cost-optimal

energy renovation measures; 3. Creation of the building model and definition of 2050 scenarios; 4. Development of the heat generation mix model and the creation of 2050 scenarios; 5. Integration of the buildings model and the heat generation mix model. Detailed descriptions of the methodology are found in [7], [20], [21].

The main result of this case study highlights that:

- i) an energy system integrated approach is necessary to avoiding early retirement of assets or new unnecessary investments;
- ii) a long-term perspective is crucial to involve all the stakeholders in the decision process and to properly plan and implement future investments;
- iii) Geographic Information System (GIS) tools are extremely useful for local energy planning applications since they allow calculating geometrical data and catching the spatial peculiarities of different districts;
- iv) finding synergies between energy saving measures and new investments in the heat supply mix in Europe is

fundamental. This will permit to re-think current building policies to support the progressive decarbonisation of the supply sector

Moreover, it worthwhile highlighting that an integrated approach is specifically needed in district heated cities where district heat strategies will probably face long-term load variations. In some cases, when demand variations occur, it is possible to expand the heat network to ensure the minimum operation of base load capacity. However, in other cases, this is not possible for many reasons (i.e. heritage constrains, rivers, already saturated areas etc.). Therefore, particular attention should be devoted to the understanding of district heat expansion possibilities.

2.2 Evaluation of retrofit strategies for the building sector

This paragraph describes two kinds of analyses applied to an urban district in order to identify the best retrofit strategy from a socio-economic and environmental point of view.

The neighborhood chosen for the analysis is a residential district with an area of approximately 8 hectares, characterized by high-rise apartment buildings built before 1980 and different for typology and use. Four different retrofit scenarios were hypothesized combining two levels of thermal insulation for the envelope and two alternative solutions for the generation system (one consists of district heating and domestic hot water production, biomass oil circuit recloser cogeneration system, biomass thermal system and photovoltaic system; the other one district heating and domestic hot water production, gas turbine cogeneration system, gas thermal system and photovoltaic system).

In the first study [22], a CBA was applied identifying the costs and benefits of the four scenarios, estimating the monetary values, distributing the estimated costs and benefits over the time and constructing the cash flow, defining the discount rate and calculating the performance indicators. With specific reference to the performance indicators, the Social Return on Investment (SROI) was chosen; it aims to make a clear relationship between the monetary investment to make a retrofit intervention and the impacts return, translated into monetary terms. In particular, the benefits taken into account were energy savings, CO₂ emissions' savings, energy bill and maintenance and disposal costs reduction, increasing the real estate market value, green jobs' creation by building retrofit.

In the second study [23], an MCDA was developed exploiting the PROMETHEE method (Preference Ranking Organization Method for Enrichment Evaluations) that permits to evaluate several alternative retrofit scenarios

according to different criteria, that are not all expressed in monetary values. Two main types of information characterize the method: the preference weight assumed by the decision-maker about a specific criterion, to determine the relative importance of one over another, and the preference function for each criterion, that allows establishing how much an alternative is preferred over another. The evaluated criteria consist of energy performances, CO₂ emissions, global cost value, indoor comfort, energy surplus production, green jobs' creation, real estate market value. Four experts were consulted: an energy efficiency expert, an occupant behaviour expert, an economic evaluator and a built environment expert.

Referring to the Torino case study, the results of the two different analyses are aligned and consist in the scenario related to the biomass exploitation. It is interesting to notice that originating from a different methodological background, both approaches succeed in broadening the evaluation perspective and aggregate in a single indicator the overall performance of each alternative retrofit scenario. The CBA approach is more complex to apply compared to the MCDA one, due to the difficulties in identifying and quantifying the main costs and benefits and translating them into monetary value.

3. CONTEXT: RESULTS FROM DIMMER AND FLEXMETER PROJECTS

Smart energy use in the urban district city will take advantage of a fast-growing deployment renewable energy sources. In this context, Information and Communication Technologies (ICTs) play a crucial role in both planning and monitoring of distributed energy sources. The deployment of renewable sources affects substantially the operation of electricity networks: i) the direction of power flows can be inverted, ii) voltage profiles are modified, iii) fault management is affected. Moreover, System Operators are also enhancing the ICT layer used to monitor and control distribution networks. Those changes imply the need for distribution network to become Smart with the use of metering infrastructures, implementation of new control policies and technologies to be tested before a real implementation. In this context during the DIMMER [24], [25] and FlexMeter [26] EU projects, we developed a flexible architecture for smart-grid co-simulation in real-time [27], that integrates also a software infrastructure to simulate Photovoltaic systems production [10], [28], [29].

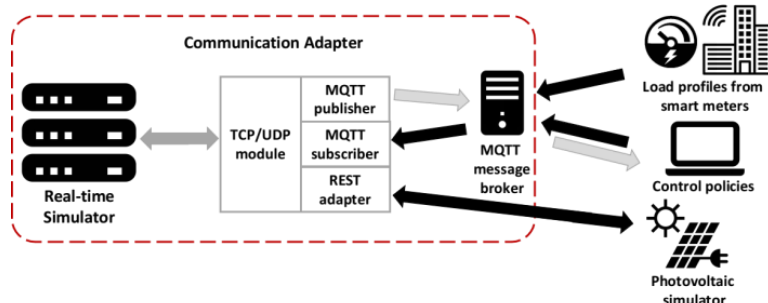

Figure 2. Schematic of the proposed distributed infrastructure for real-time co-simulations in smart grids

As shown in Figure 2, we identify five main distributed components for the proposed infrastructure: i) *Real-Time*

Simulator, ii) *Communication Adapter*, iii) *Load Profiles form Smart Metering architectures*, iv) *Photovoltaic Simulator*

(PVsim) and v) *Control and management algorithms*. The rest of this Section describes each component of the proposed infrastructure in more detail.

3.1 Real-time simulator

The Real-Time Simulator (RTS) is in charge of reproducing the behaviour of a real electric distribution system, which is modelled as a test bed for testing and validation of new technologies, management algorithms or control strategies, through performing software in-the-loop (SIL) or hardware in-the-loop (HIL). In SIL, an algorithm or a control strategy is tested on a real-time model of the system. In this way, validation is carried out safely, and from a variety of different scenarios which may not be all feasible or available in the real world. In HIL similar tests can be performed, connecting physical devices to the simulated environment. In our proposed architecture, the real-time simulation module is mainly in charge of reproducing the distribution grid behavior from a physical infrastructure perspective. Section 3.2 presents the Communication Adapter, which is our software solution to enable bidirectional communication between the real-time simulator and other services and/or devices.

3.2 Communication adapter

The Communication adapter (see Figure 2) is in charge of enabling data exchange among the Real-time simulator and other infrastructure modules. It implements two communication paradigms: i) publish/subscribe based on MQTT (Message Queuing Telemetry Transport) protocol and ii) request/response based on REST (Representational State Transfer). In its core, the Communication adapter exploits the TCP/UDP module to allow a bidirectional communication with the RTS. This module implements both server and client functionalities, in that it receives and sends data to the real-time simulation engine. Such data includes either electrical measurement from virtual meters in the grid model or control signals from some control and management algorithms. The Communication adapter provides the MQTT publisher module that parses data from RTS into a sequence of events before publishing to an MQTT Message broker.

The Message broker keeps track of all publications and subscriptions and takes care of sending new data to subscribers. The Communication adapter works also as a subscriber. Therefore, it is able to receive commands from remote applications (e.g. Control and managements algorithms) and pushes them to the real-time simulation engine. Finally, the REST adapter is in charge of retrieving information from REST web service, even third party services, and passes the results to RTS, again through the TCP/UDP module.

It is worth noting that the Communication adapter allows the integration of the Real-time simulator with Flexmeter, our proposed Smart Metering Architecture (see Section 3.3), where each smart meter is an Internet-of-Things (IoT) device. Hence, data coming from such devices can be used to simulate and test innovative control strategies with (near-) real-time data from the grid.

3.3 Load profiles from smart metering architectures

Flexmeter is a flexible smart metering architecture for smart cities. It is a distributed IoT platform that collects and integrates heterogeneous information from multiple energy to

foster innovative services. In this view, the platform is in charge of: i) integrating different devices; ii) correlating data from smart meters of different utilities; iii) providing advanced services to end-users (i.e. consumers, prosumers and Distribution System Operators); iv) enhancing the retail market. As shown in Figure 3, it is a three-layered distributed architecture that exploits both request/response and publish/subscribe communication paradigms. It consists of: i) *IoT Devices Layer*; ii) *Middleware Layer*; iii) *Services Layer*. Flexmeter is a multi-tenant and multi-protocol open platform for the Internet-of-Things.

The *IoT Devices Layer* consists of IoT devices (i.e. heterogeneous smart meters) integrated into the platform that transfers data via the Message Broker exploiting the MQTT protocol. The *Middleware Layer* provides features to manage devices, collects information in scalable NoSQL or time-series databases and access them through REST API. Finally, the *Services Layer* exposes modules to address energy flows management and user awareness. Indeed, the algorithms running in this layer are devoted to demand- response and fault detection that may occur across the entire energy distribution network.

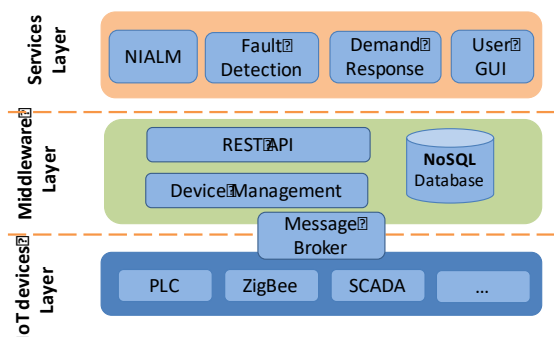

Figure 3. Flexmeter platform architecture

3.4 Photovoltaic simulator

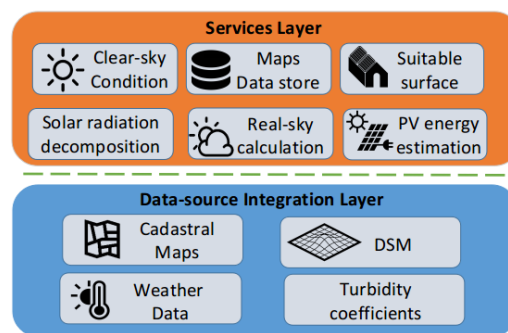

Figure 4. Schematic of the PVsim software architecture

The *Photovoltaic Simulator* (PVsim) is a distributed infrastructure to estimate the Photovoltaic (PV) energy potential in urban areas. It has been designed following both microservice [30] and REST [31] design patterns to easy the integration with the smart-grid co-simulation infrastructure or with third-party solutions. As shown in Figure 4, PVsim is composed of two layers described in the following.

The **Data-source Integration Layer**, the lower layer, integrates the following data-sources: i) Digital Surface Model (DSM) of the area in study (A raster image that represents terrain elevation); ii) Linke Turbidity coefficients that express the attenuation of solar radiation related to air pollution; iii)

Weather Data coming from the nearest weather station provided by third-party services; iv) cadastral map of existing buildings.

The **Services Layer** is composed of a set of micro-services that communicates through REST-API. The *Clear-Sky condition* service exploits the r.sun tool of GRASS-GIS to calculate maps representing incident solar radiation every 15 minutes in the area of interest in clear sky condition. Such maps are stored in the *Maps Data-store* ready to be used by the other components. *Suitable Area* service identifies suitable real rooftop surfaces for deploying PV system. *Solar radiation decomposition* service is in charge of decomposing global horizontal radiation (GHI) in Direct Normal Radiation (DNI) and Diffuse Horizontal Radiation (DHI). It is used if the nearest weather station provides only GHI. The *Real-sky condition* service produces real-sky maps for each time interval of the simulation. Finally, *PV energy estimation* service using the results of the *Real-sky condition* service and suitable area service calculates the produced power by the PV systems.

3.5 Control and Management Algorithms

Figure 2 shows how the proposed distributed simulation architecture can support decision making for development and improvement of electric distribution systems control and management, especially in emerging smart grids with a considerable amount of distributed generation. The virtual model of the grid can be built and simulated in real-time thanks to the available data from the real world system. A variety of different control or management strategies can be then considered within this framework. The applications could include emerging methodologies in distribution systems automation, distributed and centralized state estimation processes, storage management, demand response, network reconfiguration, outage management strategies including fault and outage location algorithms, etc.

3.6 Results

The proposed integrated simulation platform has been applied to study a high PV penetration simulating the distribution grid behavior in a part of "La Crocetta" district located in Torino. The analyzed area counts nearly 2200 residential buildings and 43 MV/LV substations. In order to stress the grid behavior and evaluate the maximum level of self-sufficiency a summer sunny day has been selected. In Figure 5 and Figure 6 the levels of self-sufficiency and violation of transformer capacity are presented. Figure 5 shows that the substation with less production has less than 10% of self-sufficiency. However, substations 17, 18, 23, 24 and 25 have a level of self-sufficiency over 39%. The transformer capacity map (Figure 6) shows that in substations 17 and 25, if all the PV generation were deployed, violations of the capacity will occur. This will happen because in these two substations there is a high amount of PV generation and low consumption. In order to avoid this violation or the maximum power of deployable PV systems is reduced or the transformers, cables and lines must be changed. High penetration of PV can affect the voltage control of the grid. In this case, the study revealed that local generations with respect to local consumption are not equally/closely distributed in two feeders of the same transformer as shown in Figure 7. Hence, any change in the level of transformer voltage used to correct

voltage in one feeder would result in more deviation in the other feeder.

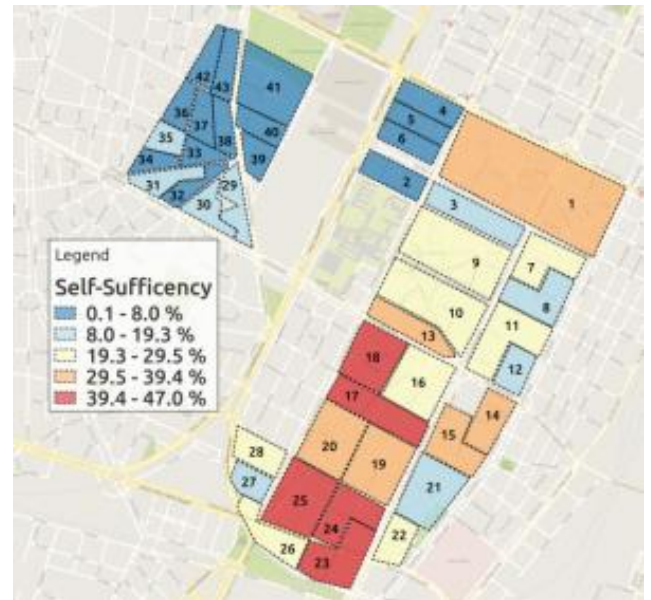

Figure 5. Self-sufficiency map



Figure 6. Transformer violation capacity map

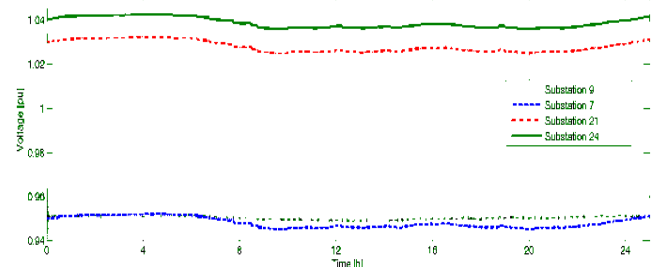

Figure 7. Voltage profiles

4. BIOWASTE-TO-ENERGY: THE DEMOSOFC PLANT

4.1 Context

A central point of the circular economy approach is to make use of waste streams (solid, liquid, gas) as primary sources for downstream processes. In this sense, the anaerobic digestion of waste from municipal processes, such as the biogas stream produced by municipal wastewater treatment plants, represent a very peculiar waste-recovery attitude of urban municipalities. The recovered biogas represents a suitable fuel for processes of energy production (CHP). Adopting the technology assuring the highest energy valorization of these waste streams is an important challenge. In this context, Solid Oxide Fuel Cell (SOFC) systems seem to represent the best option for the energy recovery from biogas [32], [33]. Furthermore, looking at the biogas potential in EU, the most common anaerobic digestion plant size is in the sub-MW scale, which is exactly the size where the efficiency of SOFC-based systems outperforms one of the thermal plants with a value of around 20% points.

In this context, DEMOSOFC is an H2020 funded project related to the installation and operation of the largest biogas-fed Solid Oxide Fuel Cell (SOFC) in Europe. The plant is installed in a real industrial environment: the wastewater treatment plant located in Torino (IT). Three SOFC modules, each rated 58 kW_e (for a total of 174 kW_e) with a total heat recovery of around 90 kW_{th}, will guarantee the supply of 30% of the internal electrical loads and 50-100% of the thermal load depending on the season. Figure 8 describes the concept of the plant.

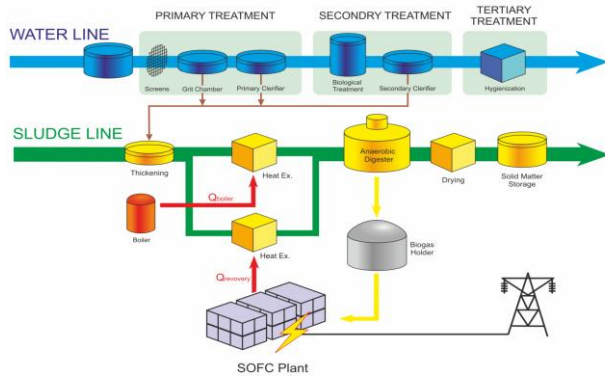

Figure 8. Concept of the ‘biowaste-to-energy’ plant in Torino (DEMOSOFC project: www.demosofc.eu)

4.2 Description of the plant

The plant is installed within a medium size wastewater treatment plant (WWTP) located in Torino (IT). This WWTP serves 270'000 equivalent inhabitants collecting an overall of 59'000 m³ of wastewater on a daily basis that corresponds to ~220 liter/day/capita. The DEMOSOFC system has three main sections (Figure 9) [34]. The biogas clean-up section is required to remove biogas contaminants - which could be harmful to the SOFC - like sulfur, siloxanes and halogenated compounds, down to ppb(v) levels. The clean-up section was designed with a lead- and- lag reactors' configuration that is able to match the advantages of both a parallel and series configuration and have an active safety double vessel layout. Selectively activated carbons for sulfur and siloxanes removal

have been selected and a continuous online gas analyzer is able to detect the real-time state of the adsorption bed and ensure substitutions only when required. The SOFC modules are fed with compressed biogas and ambient air, delivering AC power. The electrochemical high-efficiency reaction produces electrical power with an efficiency equal or higher than 53%, from full to half load. The heat recovery section recovers and transfers high temperature heat from the SOFC exhaust to the mesophilic anaerobic digester, where biogas is produced. The digester is not directly heated but thermal power is supplied by heating up the fresh sludge entering the reactor. The system is able to entirely cover summer and shoulder season's loads, while additional natural gas will be required during winter.

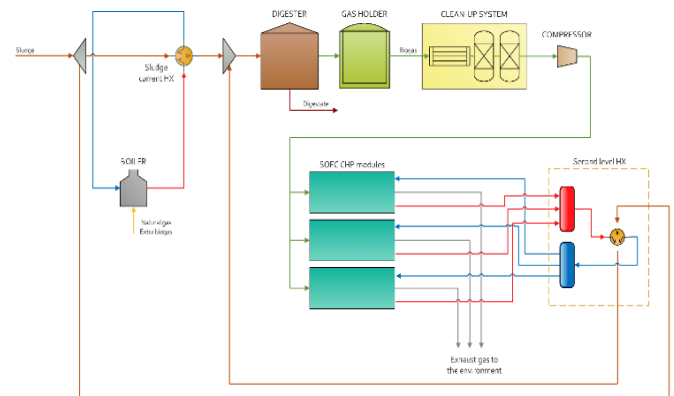

Figure 9. Schematic diagram of the DEMOSOFC installation

4.3 Discussion

Table 1. Energy efficiency of the Solid Oxide Fuel Cell compared to conventional power technologies

	Micro Gas Turbine	Internal Combustion Engine	Solid Oxide Fuel Cell
Electrical efficiency	28.0%	38.5%	53%
Thermal efficiency	45.9%	23.3%	27% (37% with further cooling)
Total efficiency	74%	62%	80% (90% with further cooling)
CO ₂ emission [gCO ₂ /kWh _e] with the system fed by NG	798	580	422

Table 2. Emission of atmospheric pollutants: ICE vs. SOFC (ICE = internal combustion engine; SOFC = solid oxide fuel cell)

Contaminant	Emissions with ICE fed by biogas	Emissions with SOFC fed by biogas
Total PM	2.31 mg/Nm ³	-
NO _x	443 mg/Nm ³	< 1.23 mg/Nm ³
SO _x	25.8 mg/Nm ³	negligible
CO	353 mg/Nm ³	< 12.31 mg/Nm ³
H ₂ S	< 0.2 mg/Nm ³	-
VOC	659 mg/Nm ³	< 2.46 mg/Nm ³
HCl	0.38 mg/Nm ³	-
HF	< 0.2 mg/Nm ³	-

The good practice coming from this plant is strictly linked to innovation in power generation connected to waste management. The DEMOSOC plant highlights the paradigm of distributed power generation with high efficiency and low carbon emissions. In addition, the SOFC technology is one of

the options now available in terms of electrical and global efficiency, especially at sub-MW scale (see Table 1).

The highest efficiency of an SOFC system assures a dramatic reduction of CO₂ emissions if compared to the competing technologies (mainly ICE and GT). Moreover, DEMOSOFC project foresees the adoption of biogas from wastewater treatment of sewage sludge, operating thus as a CO₂-neutral plant. In terms of emission of atmospheric pollutants, the SOFC solution is for sure highly advantageous: the SOFC has practically no NO_x, SO_x, PM or VOC emissions.

The potential for distributed power generation in the urban environment could further enhanced by exploiting the organic fraction of municipal solid waste (OFMSW). Biogas from the anaerobic digestion of OFMSW is another opportunity to increase the generation of power. Interestingly, OFMSW could be co-digested in already available digesters at the wastewater treatment plants [35].

5. CONCLUSIONS

Promoting effective energy policy instruments at the urban scale is key to achieve an improved energy performance and lower carbon footprint of cities [36,37]. Assessing first the public stock of buildings can be more effective, since it provides a non-negligible share of the overall urban stock and it involves only one stakeholder. However, the set of policy measures should then extend to the whole urban building stock and to mobility as well.

In this work, we reviewed a number of measures currently on going or simulated for the city of Torino with the goal of improving urban energy use. The building and mobility sector are highly energy-intensive. However, the integration of renewable energy (PV, biogas) in the urban texture coupled with smart energy systems management can reduce emissions of CO₂ harmful atmospheric contaminants. Practical experience is thus already available. Long-term and strategic energy plants of the cities is now required to assure a feasible transition to smarter and more sustainable urban settlements.

REFERENCES

- [1] UN Habitat - Energy. [Online]. Available: <https://unhabitat.org/urban-themes/energy/>. Accessed: 28-May-2017.
- [2] *The World's Cities in 2016 - Data Booklet (ST/ESA/SER.A/392)*. United Nations, Department of Economic and Social Affairs, Population Division.
- [3] Creutzig F., Baiocchi G., Bierkandt R., Pichler P.-P., Seto K.C. (2015). Global typology of urban energy use and potentials for an urbanization mitigation wedge, *Proc. Natl. Acad. Sci.*, Vol. 112, No. 20, pp. 6283-6288.
- [4] Blasius E. (2017). Possible role of power-to-vehicle and vehicle-to-grid as storages and flexible loads in the German 110 kV distribution grid, *Front. Energy*, Vol. 11, pp. 146-154.
- [5] Fernandes A., Woudstra T., van Wijk A., Verhoef L., Aravind P.V. (2016). Fuel cell electric vehicle as a power plant and SOFC as a natural gas reformer: An exergy analysis of different system designs, *Appl. Energy*, Vol. 173, pp. 13-28.
- [6] Oldenbroek V., Verhoef L. A., van Wijk A. J. M. (2017). Fuel cell electric vehicle as a power plant: Fully renewable integrated transport and energy system design and analysis for smart city areas, *Int. J. Hydrogen Energy*, Vol. 42, No. 12, pp. 8166-8196.
- [7] International Energy Agency (2016). *Toward Sustainable Urban Energy Systems, Energy Technology Perspectives (ETP) 2016*.
- [8] Becchio C., Corgnati S.P., Delmastro C., Fabi V., Lombardi P. (2016). The role of nearly-zero energy buildings in the transition towards Post-Carbon Cities, *Sustain. Cities Soc.*, Vol. 27, pp. 324-337.
- [9] The heat is on (2016). *Nat. Energy*, Vol. 1, No. 12, p. 16193.
- [10] Bottaccioli L., Macii E., Patti E., Estebarsari A., Pons E., Acquaviva A. (2017). PVInGrid: A distributed infrastructure for evaluating the integration of photovoltaic systems in smart grid, pp. 316-324.
- [11] Rotunno P., Lanzini A., Leone P. (2017). Energy and economic analysis of a water scrubbing based biogas upgrading process for biomethane injection into the gas grid or use as transportation fuel, *Renew. Energy*, Vol. 102, pp. 417-432.
- [12] Sørnes K., Sartori I., Fredriksen E., Martinsson F., Romero A., Rodriguez F., Schneuwly P. (2016). Final report on common definition for nZEB renovation: ZenN: Nearly Zero Energy Neighborhoods: D.1.2 Report.
- [13] Marique A.F., Penders M., Reiter S. (2013). From zero-energy building to zero-energy neighbourhood: urban form and mobility matter, *Proceedings of the International PLEA Conference*, Munich, pp. 1-6.
- [14] Mistry J., Tschirhart C., Verwer C., Glastra R., Davis O., Jafferally D., Haynes L., Benjamin R., Albert G., Xavier R., Bovolo I., Berardi A. (2014). Our common future. Cross-scalar scenario analysis for social-ecological sustainability of the Guiana Shield, South America, *Environ. Sci. Policy*, Vol. 44, pp. 126-148.
- [15] Miola A. (2008). *Backcasting Approach for Sustainable Mobility*. Joint Research Centre.
- [16] Delponte I., Pittaluga I., Schenone C. (2017). Monitoring and evaluation of Sustainable Energy Action Plan: Practice and perspective, *Energy Policy*, Vol. 100, pp. 9-17.
- [17] Harrestrup M., Svendsen S. (2014). Heat planning for fossil-fuel-free district heating areas with extensive end-use heat savings: A case study of the Copenhagen district heating area in Denmark, *Energy Policy*, Vol. 68, pp. 294-305.
- [18] Jank R. (2000). ANNEX 33 Advanced Local Energy Planning (ALEP) reinhard jank. A guidebook, International Energy Agency.
- [19] Mirakyan A., De Guio R. (2013). Integrated energy planning in cities and territories: A review of methods and tools, *Renew. Sustain. Energy Rev.*, Vol. 22, pp. 289-297.
- [20] Delmastro C., Mutani G., Corgnati S.P. (2016). A supporting method for selecting cost-optimal energy retrofit policies for residential buildings at the urban scale, *Energy Policy*, Vol. 99, pp. 42-56.
- [21] Mutani G., Delmastro C., Gargiulo M., Corgnati S.P. (2016). Characterization of building thermal energy consumption at the urban scale, *Energy Procedia*, Vol. 101, No. September, pp. 384-391.
- [22] Becchio C., Bottero M., Corgnati S.P., Dell'Anna F. (2016). Cost benefit analysis and smart grids projects,

Proceedings of Sustainable Built Environment: Towards Post-Carbon Cities, pp. 278-287.

- [23] Becchio C., Bottero M., Corgnati S. P., Dell'Anna F. (2017). A MCDA-based approach for evaluating alternative requalification strategies for a net-zero energy district (NZED), Springer International Publishing, pp. 189-211.
- [24] Patti E., Ronzino A., Osello A., Verda V., Acquaviva A., Macii E. (2015). District information modeling and energy management, *IT Prof.*, Vol. 17, No. 6, pp. 28-34.
- [25] Brundu F.G., Patti E., Osello A., Del Giudice M., Rapetti N., Krylovskiy A., Jahn M., Verda V., Guelpa E., Rietto L., Acquaviva A. (2017). IoT Software Infrastructure for Energy Management and Simulation in Smart Cities, *IEEE Trans. Ind. Informatics*, Vol. 13, No. 2, pp. 832-840.
- [26] Patti E., Acquaviva A. (2016). IoT platform for Smart Cities: Requirements and implementation case studies, in *2016 IEEE 2nd International Forum on Research and Technologies for Society and Industry Leveraging a better tomorrow (RTSI)*, pp. 1-6.
- [27] Bottaccioli L., Estebasari A., Pons E., Bompard E., Macii E., Patti E., Acquaviva A. (2017). A flexible distributed infrastructure for real-time co-simulations in smart grids, *IEEE Trans. Ind. Informatics*, pg. 1.
- [28] Bottaccioli L., Estebasari A., Patti E., Pons E., Acquaviva A. (2017). A Novel integrated real-time simulation platform for assessing photovoltaic penetration impacts in smart grids, *Energy Procedia*, Vol. 111, pp. 780-789.
- [29] Bottaccioli L., Patti E., Grosso M., Rasconà E., Marotta G., Rinaudo A., Acquaviva S., Macii A. (2016). Distributed software infrastructure for evaluating the integration of photovoltaic systems in urban districts, *SMARTGREENS 2016*.
- [30] Fowler M., Microservices. [Online]. Available: <https://martinfowler.com/articles/microservices.html>. Accessed: 03-Jun-2017.
- [31] Fielding R.T., Taylor R.N. (2002). Principled design of the modern Web architecture, *ACM Trans. Internet Technol.*, Vol. 2, No. 2, pp. 115-150.
- [32] Lanzini A., Madi H., Chiodo V., Papurello D., Maisano S., Santarelli M., van Herle J. (2017). Dealing with fuel contaminants in biogas-fed solid oxide fuel cell (SOFC) and molten carbonate fuel cell (MCFC) plants: Degradation of catalytic and electro-catalytic active surfaces and related gas purification methods, *Prog. Energy Combust. Sci.*, Vol. 61, pp. 1-6.
- [33] Curletti F., Gandiglio M., Lanzini A., Santarelli M., Maréchal F. (2015). Large size biogas-fed Solid Oxide Fuel Cell power plants with carbon dioxide management: Technical and economic optimization, *J. Power Sources*, Vol. 294, pp. 669-690.
- [34] Mehr A.S., Gandiglio M., MosayebNezhad M., Lanzini A., Mahmoudi S.M.S., Yari M., Santarelli M. (2017). Solar-assisted integrated biogas solid oxide fuel cell (SOFC) installation in wastewater treatment plant: Energy and economic analysis, *Appl. Energy*, Vol. 191, pp. 620-638.
- [35] Sosnowski P., Wieczorek A., Ledakowicz S. (2003). Anaerobic co-digestion of sewage sludge and organic fraction of municipal solid wastes, *Adv. Environ. Res.*, Vol. 7, No. 3, pp. 609-616.
- [36] Ascione F., Bianco N., De Stasio C., Mauro G.M., Vanoli G.P. (2016). A methodology to assess and improve the impact of public energy policies for retrofitting the building stock: application to Italian office buildings, *International Journal of Heat and Technology*, Vol. 34, Special Issue 2, pp. S277-S286. DOI: [10.18280/ijht.34Sp0213](https://doi.org/10.18280/ijht.34Sp0213)
- [37] Delmastro C., Mutani G., Perassi S. (2016). In use monitoring of public buildings. Case study in North Italy, *International Journal of Heat and Technology*, Vol. 34, Special Issue 2, pp. S266-S276. DOI: [10.18280/ijht.34Sp0212](https://doi.org/10.18280/ijht.34Sp0212)