

Labview-based Study on the Modeling Method of Chlorophyll Content Prediction in Tomato Leaves

Ji Qian, **Juan Zhou, ***Yang Liu

*College of Horticulture, Hebei Agricultural University, Baoding 071000, China

(qianji167@163.com)

**College of Mechanical & Electrical Engineering, Hebei Agricultural University, Baoding

071000, China

***Department of Software Engineering, Software Institute of Hebei, Baoding 071000, China

Abstract

The traditional measuring method of chlorophyll content is cumbersome and time-consuming. Taking the labview software and IMAQ-Vision toolkit as the platform and the tomato leaves as test materials, this paper adopts the computer vision technology to extract the component value of the tomato leaf image under different color spaces and employs the statistical analysis method to establish the correlation and regression equation between the image component and the chlorophyll content. It is obtained that the regression equation between the SPAD value and the leaf color characteristic parameter $H/(S+L)$ is $y=0.0003x^2-0.0139x+0.3411$, whose maximum coefficient of determination is $R^2=0.7327$. It is indicated that the method is effective and feasible for the prediction of tomato chlorophyll and also lays the foundation for the development of crop growth monitoring instrument.

Key words

Tomato leaf, Chlorophyll, Computer vision, Labview.

1. Introduction

Computer vision technology has been studied and applied to agriculture in the late 1970s. The main research areas are the classification and quality inspection of the agricultural products such as cucumber, tomato, wild peach and banana, some of which have achieved substantial results [1-2]. There are also some domestic and foreign reports of the research on computer vision technology, which includes the realization of intelligent identification of grape leaf disease through digital analysis of color images [3], the identification and analysis of citrus diseases by image color characteristics [4] and the auto-classification of potatoes based on visual technology [5], etc. Li Shaokun et al. expanded the application of computer vision technology into the field crops to extract the plant type information and monitor the growth of plants. Chlorophyll as the basic composition of plant leaves is mainly present in the chloroplast of plant cells and closely associated with the photosynthetic process, utilization of solar radiation energy, absorption of atmospheric CO₂ and detection of plant nutrition. It is the indispensable pigment in the photosynthesis of plants and the important nitrogen substance in the plant leaves, thus being able to accurately indicate the absorption and utilization of plant nitrogen nutrition [6-7]. The lack of nutrient elements or the external unfavorable interference can be manifested by the color and the chlorophyll content of plant leaves [8-9]. Therefore, it is of great significance to explore the modeling method of chlorophyll content prediction of tomato leaves based on the Labview software platform and the computer visual technology to substitute the time-consuming and laborious chemical analysis method.

2. Materials and Methods

2.1 Test Materials

The materials used in this experiment are Jiaxina cherry tomato plants from the solar greenhouse of the vegetable cultivation base in Sanhe City, Hebei Province (E117°, N39.97°), where the substrate soilless culture and drop irrigation are adopted. The colonization and routine management of the plants began in the mid-October 2015; in early January 2016, the leaves were collected and processed for preservation; and the experiment was completed at the end of January. The indoor and outdoor temperature difference of the greenhouse, small in the morning and in the

evening, reaches 5-7□ at noon with the indoor humidity being about 60%.

2.2 Test Methods

2.2.1 Hardware Option

Based on the study of the optical properties in the greenhouse, the computer vision hardware system suitable for chlorophyll detection of plant leaves is selected on the basis of four aspects of light quality, light intensity, sunlight hours and light distribution. This experiment adopts the NI (National Instruments) EVS-1464 processing platform, which provides the IEEE (Institute of Electrical and Electronics Engineers) 1394 camera manufactured by Basler Technologies.

The SDAD value of the leaves is measured by SPAD502 chlorophyll meter manufactured by KONICA MINOLTA Company of Japan.

The determination of chlorophyll is carried out simultaneously with tomato leaf image acquisition. When measuring leaves with chlorophyll meter, the main veins and leaf edges on the leaves must be excluded to ensure light penetration. Each tomato leaf is measured 8 times.

2.2.2 Image Acquisition

To ensure adequate overall brightness and uniform lighting, the closed light-proof black box supplemented by the KD008A-11W energy-saving lamp is adopted during the image acquisition of leaves, to achieve the uniform illumination of the lighting system and avoid strong reflections within the visual area of the camera. During the shooting, it should be avoided that the shadow of the staff or the camera falls into the vision of the camera. (See Figure 1)

During the full bearing period, we select the intact and disease-free flat leaves of similar sizes on the tomato plants, whose leaf colors are visibly different. After being sampled, the leaves are sorted into 20 numbered valve bags according to the leaf color in a descending order with six leaves of similar colors placed into each numbered bag, which are then taken back to the laboratory in the special plant safe for analysis. Some of the collected images of the tomato leaves are shown in Figure 2.

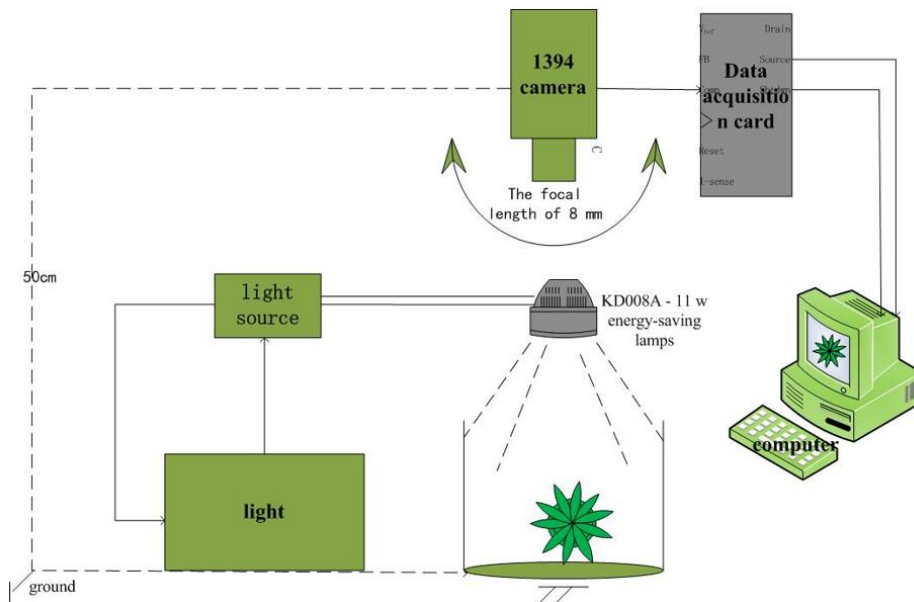
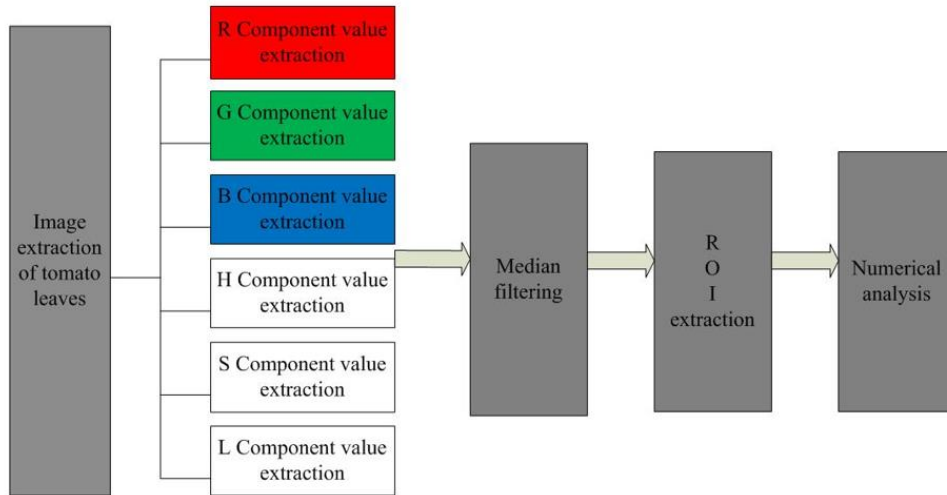

Fig.1. Image Acquisition Structure



Fig.2. A Typical Tomato Leaves Collection Image

A white cardboard is taken as the background during the shooting with the tomato leaves placed in the bottom center of the box. The camera is fixed on a 50cm-high iron frame to meet the requirements of a uniform shooting height. We necessarily check whether the fixed focus is 8mm

before every shooting to obtain images with obvious comparability. The shot images are stored in the hard disk of camera and named according to the number on the valve bag.

2.2.3 Software Design

In this experiment, the Labview is taken as the software platform and the IMAQ-Vision tool kit is taken as the image analysis and processing software to extract the characteristics (RGB, HSI) [10-11] of the tomato leaves. The system flow chart is shown in Figure 3:

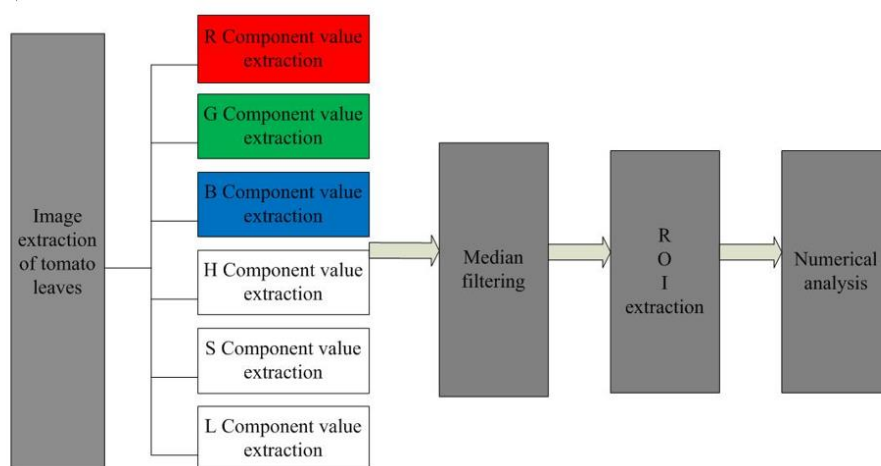

Fig.3. System Software Flow Chart

2.2.4 RGB Color Space

In this experiment, the color components of tomato leaves are extracted through the Labview and IMAQ-Vision tool kits and the correlation coefficients of RGB color models are obtained by operation and analysis. The RGB color system, which is the most commonly used color model in experiments and established on the basis of the theory of three primary colors, can produce different colors from the three primary colors by changing the contents of the tree colors. The mixed color is generally represented by the color equation [12]:

$$C^* \equiv R(R) + G(G) + B(B) \tag{1}$$

Where C * represents the color after mixing the components; \equiv indicates the visual equivalence; R, G and B represent red, green and blue, respectively. The RGB color space system

model is shown in Figure 4:

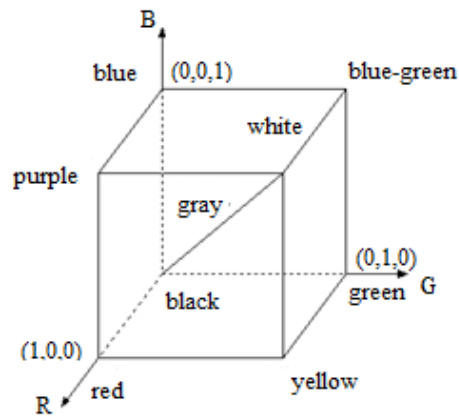

Fig.4. RGB Color Space

It is usually expressed by the scale color chromaticity coordinate (r, g, b) of R, G and B. The relationship between r, g, b and R, G, B is:

$$r = \frac{R}{R+G+B} \quad g = \frac{G}{R+G+B} \quad b = \frac{B}{R+G+B} \quad (2)$$

2.2.5 HSL Color Space

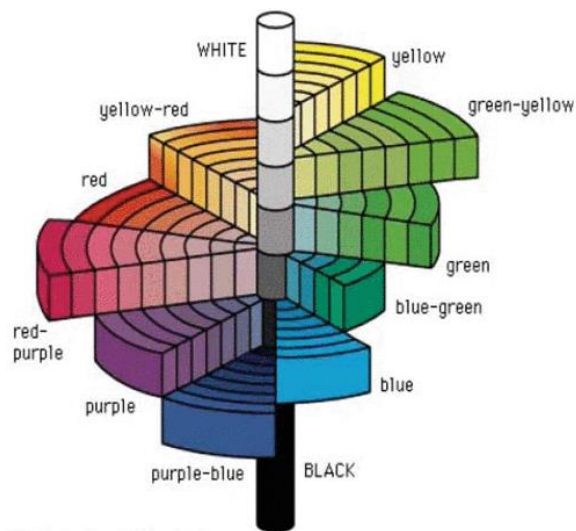

Fig.5. HSL Color Space

The HSL color system is proposed according to the human eye's working process in distinguishing different colors. Hue, saturation, and brightness are the three feature quantities used in the HSL color space model to identify different colors. The hue and saturation are collectively

referred to as chromaticity, whose combination with brightness is used to describe a certain color. The model is consistent with the double cone shown in Fig.5.

In Figure 5, H, represented by a circle, is in the range of 0° to 360° with 0° for red, 120° for green and 240° for blue; S is in the range of 0 to 1 with 1 for solid color; L is also in the range of 0 to 1 with 0 for black and 1 for white [13].

In this experiment, the R, G and B values are first extracted by the computer image processing technique. Then, the H, S and I values are obtained from the above nonlinear variation equation. Finally, the average and the standard deviation of the six components R, G, B, H, S and I are determined to prepare for the following data analysis [14].

2.2.6 Median Filter

The median filter is adopted in this experiment to conduct the image processing of tomato leaves. Median filtering is a non-linear smoothing technique, which replaces the gray value of the pixel corresponding to the center of the window with the median value. It shows great effect in the control of impulse interference and impulse noise and protection of the margin, thus ensuring the clearness of the images [14-15].

Let a one-dimensional sequence be x_1, x_2, \dots, x_n , which is arranged in accordance with the size of the number, and its median filter is defined as:

$$y = Med(x_1, x_2, x_3, \dots, x_n) = \begin{cases} x\left(\frac{n+1}{2}\right) & n \text{ odd number} \\ \frac{1}{2}\left[x\left(\frac{n}{2}\right) + x\left(\frac{n}{2} + 1\right)\right] & n \text{ even number} \end{cases} \quad (3)$$

Tab.1. The Results of All Kinds of Filters

No.	Template type	Consuming time(ms)	Effect
1	3×3 mean value template	<1	So-so
2	5×5 mean value template	<1	Poor
3	3×3 linear smoothing	<1	Poor
4	5×5 linear smoothing	<1	So-so
5	3×3 median template	12	Good
6	5×5 median template	43	Poor

This test uses a 3 × 3 square window as a window for the median filter. The following figure shows the source code of median filter, as shown in Figure 6:

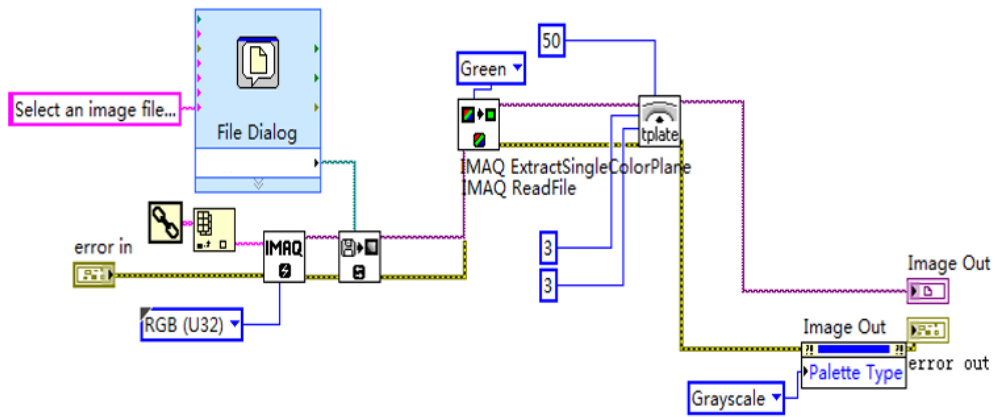

Fig.6. Median Filter Code

According to the system flow chart and image processing theory, the main test interface is designed by the Labview software platform as shown in Figure 7:

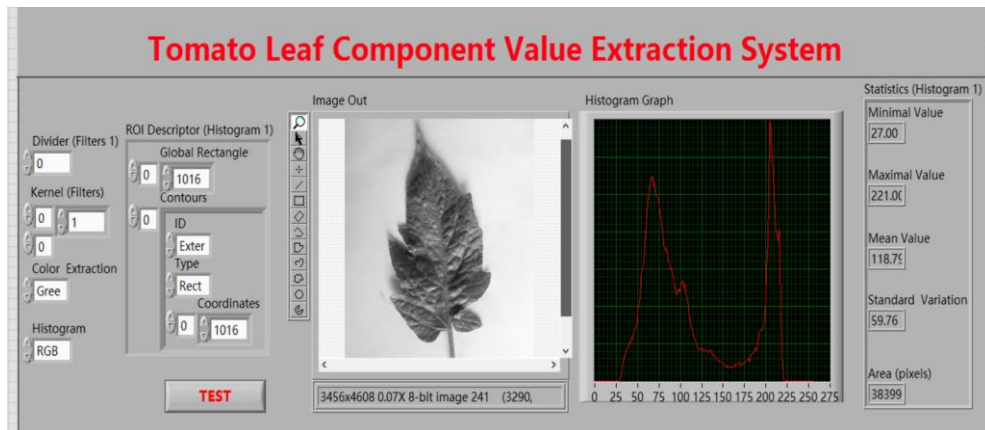

Fig.7. Test Interface Design

Part of the program is shown in Figure 8:

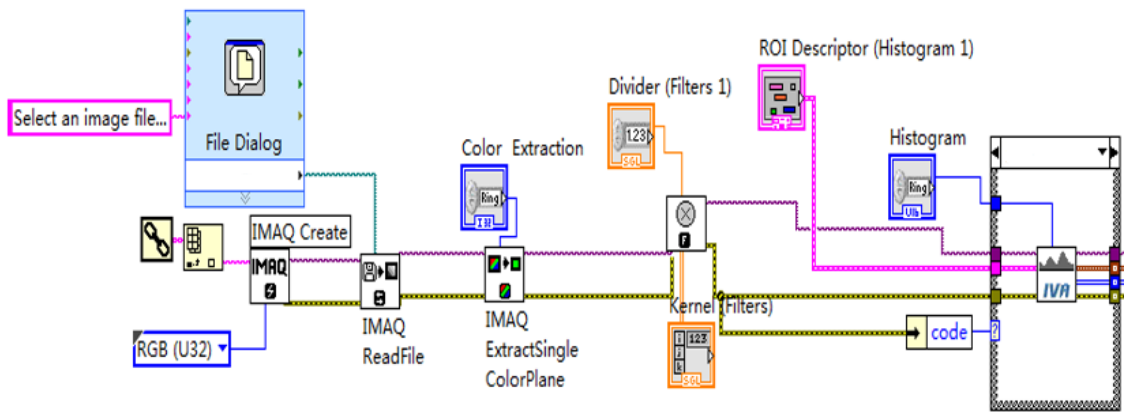

Fig.8. Method of operation

3. Results and Analysis

3.1 Picture Component Value of Tomato Leaves

The images of tomato leaves are digitized with the computer vision technology to obtain the values of the components of RGB and HSL as shown in Fig. 9:

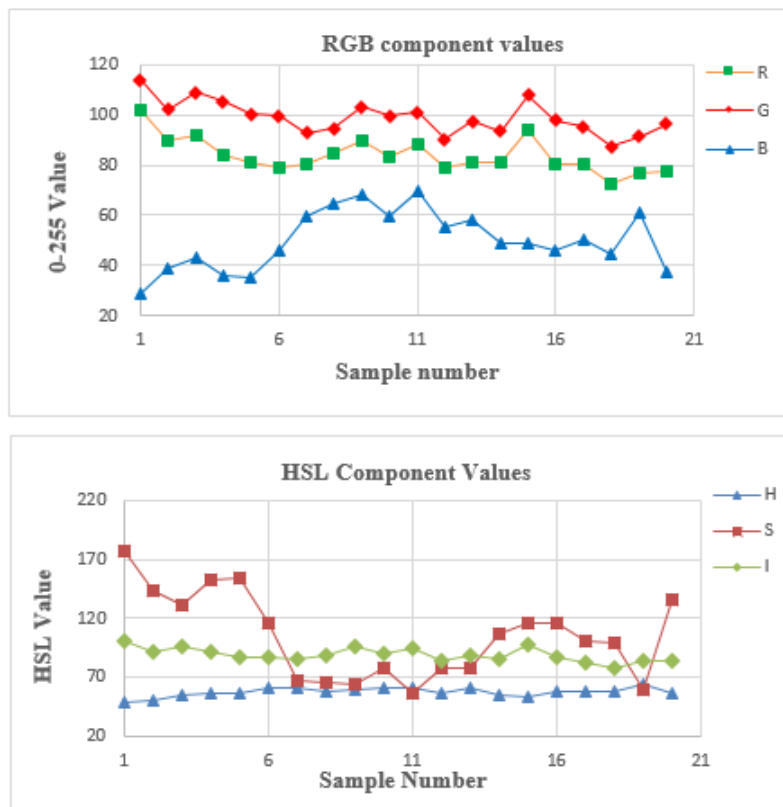

Fig.9. RGB and HSL Component Values

3.2 Chlorophyll content of tomato leaves

SPAD502 chlorophyll meter is used to measure the SDAD value of leaves as shown in Figure 10:

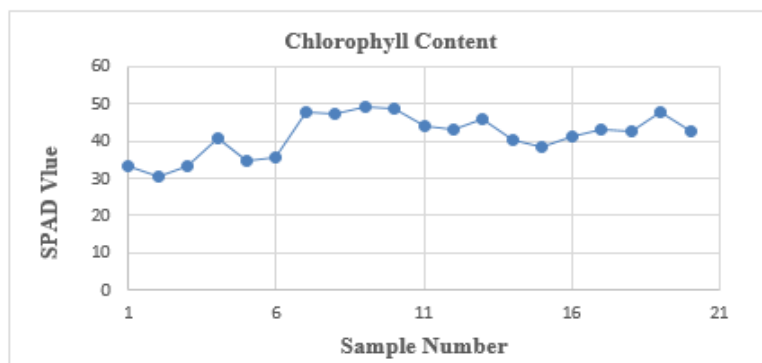

Fig.10. Chlorophyll Content

3.3 Correlation between Tomato Picture Content and SPAD Value

Since the chlorophyll content of the leaves is closely related to the absorption and reflection of light by the leaves, the SPAD values of 20 samples with visible differences in leaf surface and 12 color parameters extracted from the tomato leaf images as well as their mathematical relations are employed to carry out the correlation analysis. Table 2 shows the correlation coefficients and the regression equation at the significant level of ($\alpha = 0.01$).

Tab.2. The Results of Various Filtering Methods

Color characteristic parameter	Correlation coefficient ($\alpha = 0.01$)	Regression equation	Coefficient of determination (R^2)
B	0.796**	$y=0.3882x-22.181$	0.633
H	0.752**	$y=1.116x-22.157$	0.5652
S	-0.830**	$y=-0.1311x+55.28$	0.6892
H+S+I	-0.824**	$y=-5.1137x+462.91$	0.6792
G/(R+B)	-0.759**	$y=-0.0005x^2-0.0293x+0.4007$	0.6126
B/(G+R)	0.844**	$y=0.0102x-0.1495$	0.7112
R/(G+B)	-0.815**	$y=-0.0072x+0.8639$	0.6634
H/(S+I)	0.847**	$y=0.0003x^2-0.0139x+0.3411$	0.7347
S/(H+I)	-0.823**	$y=-0.0362x+2.2256$	0.6776
I/(H+S)	0.725**	$y=0.0147x+0.0404$	0.5253

According to Table 2, the predictive regression model of chlorophyll content of tomato leaves can be established to obtain the fitting regression equation and the coefficient of determination R^2 between the image color characteristic parameters and the SPAD value of tomato leaves. When the coefficient of determination is closer to 1, the fitting regression equation model is better. The regression equation is established with the color characteristic parameter equations whose correlation coefficient is significant and above 0.8 and the chlorophyll contents of tomato leaves.

The results show that the regression model between the SPAD value of tomato leaves and the polynomial of color characteristic parameter formula $H / (S + L)$ has the highest correlation coefficient and relatively high determinate coefficient.

4. Discussion

The results of this study show that the correlation between the color characteristic parameters and the SPAD values of the leaves obtained by RGB and HIS color space system is better than that directly obtained through the three primary colors.

In this experiment, the regression equation with the best correlation and relatively large coefficient of determination is selected through sample data collection and the Labview-based greenhouse plant image processing software.

The regression equation established with SPAD values and color characteristic parameters $H / (S + L)$ is:

$$y = 0.0003x^2 - 0.0139x + 0.3411 \quad R^2 = 0.7347$$

(4)

Image information collection is the key technology of this experiment in analyzing the characteristics of plant leaves with the Labview-based greenhouse plant image processing software. In the experimental process, we should try to maintain a relatively consistent condition for image information collection to reduce errors as much as possible, thus determining the correlation between the color component information of tomato leaves and chlorophyll and realizing the rapid detection of tomato nutrient status. Only with a leaf image containing complete information can we obtain the chlorophyll content of part of the leaf or the whole leaf, and even multiple leaves,

which demonstrates our method's advantages of low cost, flexible operation, high efficiency and high precision.

References

1. L. Chaerle, D.V.D. Straeten, Seeing is believing: Imaging techniques to monitor plant health, 2001, *Biochimica et Biophysica Acta*, vol. 36, pp. 153-166.
2. T.F. Pydipati, R. Burks, W.S. Lee, Identification of citrus disease using color features and discriminant analysis, 2006, *Computer and Electronics in Agriculture*, vol. 52, pp. 49-59.
3. P. Meunkaewjinda, K. Kumsawat, A. Attakitmongcoland, W. Grape Sriksae, Leaf disease detection from color imagery using hybrid intelligent system, 2008, *IEEE Proceeding of ECTI-CON*, vol. 47, pp. 513-516.
4. J.C. Noordam, G.W. Otten, A.J.M. Timmermans, B. Zwol, High-speed potato grading and quality inspection based on a color vision system, 2000, *Proceeding of SPIE-Machine vision application in industrial inspection VIII*, vol. 67, pp. 206-217.
5. H.Y. Zhang, J.H. Wu, Advances in nitrogen nutrition of wheat, 2006, *Chinese Agriculture Science Bulletin*, vol. 22, pp. 163-167.
6. X.H. Chen, K. Liu, Effects of nitrogen nutrition and soil moisture on photosynthetic characteristics, yield and quality of rice during grain filling stage, 2004, *Journal of Shanghai Jiao Tong University (Agricultural Science Edition)*, vol. 201, pp. 48-53.
7. J.L. Ma, H. Jiang, Effects of bamboo charcoal organic fertilizer on chlorophyll fluorescence characteristics and relative chlorophyll content of organic cabbage, 2015, *Journal of Northeast Agricultural University*, vol. 46, pp. 29-36
8. Y.Y. Liu, S.G. Luo, Under the stress of continuous cropping soybean on the absorption of nutrient elements, 1997, *Journal of Northeast Agricultural University*, vol. 28, pp. 209-215.
9. A.L. Chai, B.J. Li, Detection of chlorophyll content in tomato leaves based on computer vision technology, 2009, *Journal of Horticulture*, vol. 36, pp. 45-52.
10. X.W. Luo, Y. Zang, Z.Y. Zhou, Research progress in farming information acquisition technique for precision agriculture, 2006, *Transactions of the CSAE*, vol. 22, no. 1, pp. 67-173.

11. L.R. Teng, Q.F. Meng, *Biology experiment tutorial (Third Edition)*, 2008, Beijing: Science Press, pp. 22-23.
12. National Instruments, *IMAQ PCI/PXITM-1141 User Manual*, Austin Texas: National Instruments Corporation. 2002, pp. 13, 17.
13. F.Y. Wang, S.K. Li, K.R. Wang, Obtaining information of cotton population chlorophyll by using machine vision technology, 2007, *Acta Agronomica Sinica*, vol. 33, no. 12, pp. 2041-2046.
14. L.Y. Zheng, J.T. Zhang, Q.Y. Wang, Review on key technologies of computer vision based diagnosis of crop nutrition status, 2009, *Heilongjiang Agricultural Sciences*, vol. 2, pp. 137-140.